

Kinco

PROVEN PERFORMANCE

Customers in over 60 countries and in diverse markets and sectors.



Motion Control
Servo System

Low-voltage Servo System Catalog

-FD1X5 Servo Drive
-Low-voltage servo motor



Kinco Automation

www.en.kinco.cn Email:sales@kinco.cn

(All trademarks and logos in this brochure are property of and registered by their respective owners.)

K1E07-202502

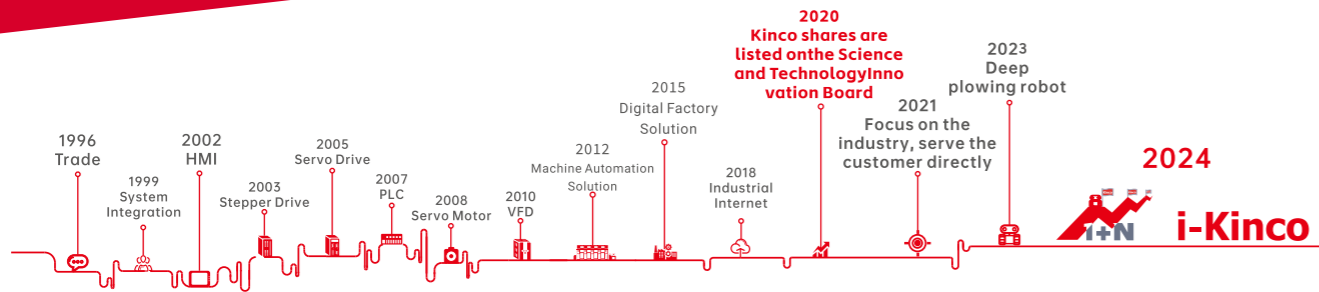

Kinco was founded in 1996, and successfully listed on the Shanghai Stock Exchange in 2020 (abbreviated name: Kinco share, stock code 688160), which is a high-tech, specialized and sophisticated enterprise that attaches great importance to independent research and development and innovation, mainly engaged in the research and development, production, sales and related technical services of industrial automation and robot core components and digital factory hardware and software. It is a leading supplier of automation control, robot power and digital factory solutions in China.

After years of continuous research and development and innovation, Kinco has established a complete product line with independent intellectual property rights, covering a series of products from machine iot to human-machine interaction, control, drive and execution, which are widely used in robots, medical equipment, logistics equipment, packaging equipment, food equipment, clothing equipment, environmental protection equipment, etc. New energy equipment, rail transit equipment and other automation equipment industry.

Based on the comprehensive industrial automation and digital technology platform, the company has in-depth application scenarios in the robot industry, providing display, control, drive and other multi-dimensional solutions for industrial mobile robots, collaborative robots, industrial robots, pan-service robots, and bionic robots. Through the insight of the industry pain points, deep links with robot customers, combined with the advantages of product research and development, the company continues to innovate, and launches industry-leading low-voltage servo products for mobile robots, integrated servo wheel, frameless torque motor for collaborative robots, robot human-machine interfaces, robot controllers and other products. The company has formed a relatively complete robot core parts capability, and after nearly 10 years of hard work in the robot industry, it has become a leading enterprise in the field of mobile robot low-voltage servo, and has a high brand influence in the industry.

Kinco has four research and development centers in Shanghai, Shenzhen, Changzhou and Chengdu, and two manufacturing bases in Shenzhen and Changzhou, a total of 10+ domestic marketing centers, 100+ domestic service providers, 40+ global partners, and products are exported to 70+ countries overseas. In terms of after-sales service, Kinco has established after-sales service centers in Shanghai, Shenzhen and Changzhou.

Four R&D centers and two manufacturing bases



FD1X5 series

New design platform, high-performance low-voltage fifth generation servo driver

FD1X5

New design platform

NEW



- ☑ Support RS485,CANopen, EtherCAT communication;
- ☑ Automatically identify motor parameters;
- ☑ Motor temperature monitoring and over temperature protection;
- ☑ Equipped with S-curve and parameter self-tuning function;
- ☑ Motor overspeed protection;
- ☑ Use Type-C debugging port.

Drive naming rule

Model: **FD 1 2 5 - AB - 000**

① ② ③ ④ ⑤ ⑥

①-Series Name	FD: FD series	④-Drive version	5: Fifth generation low-voltage drive
②-Apply voltage	1: Input Voltage DC24~60V (Input voltage: DC 72 - 110V, only suitable for FD165)	⑤ -Control mode	AB: RS485, CANopen, Have pulse, 24V logic power supply EB: EtherCAT, Have pulse, 24V logic power supply
③-Drive current	2: 15Arms 3: 30Arms 4: 50Arms 6: 65Arms	⑥ Software Version	000: Software Version Number

Note:

1. The output currents of FD125, FD135 and FD145 are 15Arms, 30Arms and 50Arms respectively, which is the value measured by installing the drive on an oxide black 6063 aluminum plate with a length*width*height of 300mm*300mm*10mm of the auxiliary heat sink.

2. The output current of the FD165 is 65Arms, and the drive needs to be installed on the auxiliary radiator with a length*width*height of 400mm*400mm*10mm and the measured value of the black oxide 6063 aluminum plate.

FD1X5 Servo driver configuration table

Rated power/ Rated current	Servo motor	Description	Power cable Brake cable	Encoder cable	Servo Drive	
					CANopen+RS485 Pulse	EtherCAT Pulse
200W/5.7A	SMK60S-0020 -30SAK-5DSA	Singleturn communication type magnetolectric encoder motor	MOT-005-LL-KA-D or MOT-005-LL-KA-DF		FD125-AB-000	FD125-EB-000
	SMK60S-0020 -30SBK-5DSA	Singleturn communication type magnetolectric encoder brake motor	MOT-005-LL-KAB-D or MOT-005-LL-KAB-DF			
400W/10.6A	SMK60S-0040 -30SAK-5DSA	Singleturn communication type magnetolectric encoder motor	MOT-011-LL-KA-D or MOT-011-LL-KA-DF	ENCHG-LL-GA 或 ENCHG-LL-GA-F	FD125-AB-000	FD125-EB-000
	SMK60S-0040 -30SBK-5DSA	Singleturn communication type magnetolectric encoder brake motor	MOT-011-LL-KAB-D or MOT-011-LL-KAB-DF			
750W/19.2A	SMK80S-0075 -30SAK-5DKA	Singleturn communication type magnetolectric encoder motor	MOT-020-LL-KA-D		FD135-AB-000	FD135-EB-000
	SMK80S-0075 -30SBK-5DKA	Singleturn communication type magnetolectric encoder brake motor	MOT-020-LL-KAB-D			
1000W/25.8A	SMK80S-0100 -30SAK-5DKA	Singleturn communication type magnetolectric encoder motor	MOT-030-LL-KA-D		FD135-AB-000	FD135-EB-000
	SMK80S-0100 -30SBK-5DKA	Singleturn communication type magnetolectric encoder brake motor	MOT-030-LL-KAB-D			
200W/5.7A	SMK60S-0020 -30QAK-5DSA	Multiturn communication type magnetolectric absolute value encoder motor	MOT-005-LL-KA-D or MOT-005-LL-KA-DF		FD125-AB-000	FD125-EB-000
	SMK60S-0020 -30QBK-5DSA	Multiturn communication type magnetolectric absolute value encoder holding motor	MOT-005-LL-KAB-D or MOT-005-LL-KAB-DF			
400W/10.6A	SMK60S-0040 -30QAK-5DSA	Multiturn communication type magnetolectric absolute value encoder motor	MOT-011-LL-KA-D or MOT-011-LL-KA-DF	ENCDG-LL-GA/ ★ENCHG-(4)-GU-DC	FD125-AB-000	FD125-EB-000
	SMK60S-0040 -30QBK-5DSA	Multiturn communication type magnetolectric absolute value encoder holding motor	MOT-011-LL-KAB-D or MOT-011-LL-KAB-DF			
750W/19.2A	SMK80S-0075 -30QAK-5DKA	Multiturn communication type magnetolectric absolute value encoder motor	MOT-020-LL-KA-D		FD135-AB-000	FD135-EB-000
	SMK80S-0075 -30QBK-5DKA	Multiturn communication type magnetolectric absolute value encoder holding motor	MOT-020-LL-KAB-D			
1000W/25.8A	SMK80S-0100 -30QAK-5DKA	Multiturn communication type magnetolectric absolute value encoder motor	MOT-030-LL-KA-D		FD135-AB-000	FD135-EB-000
	SMK80S-0100 -30QBK-5DKA	Multiturn communication type magnetolectric absolute value encoder holding motor	MOT-030-LL-KAB-D			
600W/16.5A	SMC60S-0060 -30QAK-5DSU	Multiturn communication type magnetolectric absolute value encoder motor	MOT-020-LL-KL-SP		FD145-AB-000	FD145-EB-000
	SMC60S-0060 -30QBK-5DSU	Multiturn communication type magnetolectric absolute value encoder holding motor	MOT-020-LL-KL-SP/ BRA-LL-KL			
1200W/34A	SMC80S-0120 -30QAK-5DSU	Multiturn communication type magnetolectric absolute value encoder motor	MOT-040-LL-LJ51	ENCDG-LL-GU/ ★ENCHG-(4)-GU-DC	FD145-AB-000	FD145-EB-000
	SMC80S-0120 -30QBK-5DSU	Multiturn communication type magnetolectric absolute value encoder holding motor	MOT-040-LL-LJ51/ BRA-LL-KL			
1500W/36A	SMC80S-0150 -30QAK-5DSU	Multiturn communication type magnetolectric absolute value encoder motor	MOT-040-LL-LJ51		FD165-AB-000	-
	SMC80S-0150 -30QBK-5DSU	Multiturn communication type magnetolectric absolute value encoder holding motor	MOT-040-LL-LJ51/ BRA-LL-KL			
3000W/37.5A	SMK180G-0300 -20QAK-4GSH	Multiturn communication type magnetolectric absolute value encoder motor	MOT-040-LL-LS		FD165-AB-000	-
	SMK180G-0300 -20QBK-4GSH	Multiturn communication type magnetolectric absolute value encoder holding motor	MOT-040-LL-LS/ BRA-LL-KL			
4000W/50A	SMK180G-0400 -20QAK-4GSH	Multiturn communication type magnetolectric absolute value encoder motor	MOT-080-LL-LS	ENCHG-LL-GH/ ★ENCHG-(4)-GH-DC	FD165-AB-000	-
	SMK180G-0400 -20QBK-4GSH	Multiturn communication type magnetolectric absolute value encoder holding motor	MOT-080-LL-LS/ BRA-LL-KL			
5000W/62.5A	SMK180G-0500 -20QAK-4GSH	Multiturn communication type magnetolectric absolute value encoder motor	MOT-080-LL-LS		FD165-AB-000	-
	SMK180G-0500 -20QBK-4GSH	Multiturn communication type magnetolectric absolute value encoder holding motor	MOT-080-LL-LS/ BRA-LL-KL			

Note:1. "LL" in the power line/brake line/encoder line list indicates the cable length, please refer to the model description.
 Note:2. ★ENCHG-(4)-GU-DC and ENCHG-(4)-GH-DC are essential power cable for multi turn absolute encoder motors, with a length of 40CM.
 (If the battery cable length cannot meet the requirements of the site application, extension cables can be selected.)
 Note:3. SMK80S-0100-30□■K-5DKA is recommended to match FD135, If 3 times overload is required, it needs to be matched with FD145.

FD1X5 servo driver technical parameters table



Model parameter		FD1X5 servo driver		
		FD125-□B-000	FD135-□B-000	FD145-□B-000
Rated input voltage	Power	24VDC~60VDC		
	Logic power	24VDC 1A (Optional connection or not)		
Rated output current	Maximum continuous output current (rms)	15A (Up to 12A without auxiliary cooling plate)	30A (Up to 22A without auxiliary cooling plate)	50A (Up to 35A without auxiliary cooling plate)
	Peak current (AP)	48A	100A	160A
Feedback signal		Tamagawa protocol single-turn, multi-turn encoder		
Energy consumption brake		Need external brake resistance (depending on the operation condition, mainly used in rapid start-stop occasions)		
Energy consumption brake voltage absorption point		The default is 63V		
Overvoltage alarm voltage		The default is 70V		
Undervoltage alarm voltage		The default is 18V		
Cooling mode		Natural cooling		
Weight (kg)		0.322	0.657	0.861
Logic loss power (mW)		1000	1200	1300
General function	General function	3 channels digital input, COMI terminal; High level: 12.5~30VDC; Low level: 0~5VDC; Maximum frequency: 1KHz; Input impedance: 5KΩ.		
	Input function	Freely defined as required, the functions are as follows: drive enable, drive error reset, drive mode control, speed loop proportional control, positive limit, negative limit, origin signal, command reverse, internal speed segment control, internal position segment control, emergency stop, start to find the origin, command activation, electronic gear ratio switching, gain switching		
	Pulse control	Pulse+direction, phase A+phase B (3.3V~24V)		
	Output specification	1 digital output, OUT1 is an open collector output, up to 30V, 100mA drive capability, The brake 24V DC output, with FD125, FD135, and FD145 brake ports having output current of 0.5A, 0.8A, and 1A, respectively		
	Output function	Freely defined as required, the functions are as follows:drive ready, drive error, motor position reached, motor zero speed, motor holding brake, motor speed reached, index Z signal present, maximum limit speed in torque mode, motor locked axis, motor in limit, home position found.		
	Type-C	Debug special, can use Kinco PC software connection		
	Protect function	Overvoltage protection, undervoltage protection, motor overheat (I ² T) protection, short circuit protection, drive overheat protection		
	Bus function	Modbus/RS485	It supports a maximum 115.2K baud rate and can communicate with the controller using Modbus RTU	
CANopen		It supports a maximum of 1 M baud rate and can communicate with the controller using the CANopen		
EtherCAT		Support CoE(CiA402 protocol)and CSP/CSV/PP/PV/PT/HM mode, communication speed 100M		
Installation site		Dust-free, dry, lockable (e.g. electrical cabinet)		
Installation method		Install vertically or horizontally		
Application environment	Working Temperature	-20°C~40°C (no freezing), When the operating temperature exceeds 40°C, the driver needs to be derated		
	Storage temperature	-40°C~70°C (no freezing)		
	Humidity (no condensation)	Less than 90%RH		
	Protection class	IP20		
	Altitude	The rated working altitude is less than 1000 meters above sea level. When the working altitude is higher than 1000 meters, it is necessary to reduce the rated value by 1.5% for every 100 meters of elevation. The maximum working altitude is 2000 meters above sea level.		
	Atmospheric pressure	86kpa~106kpa		
Note		□=A: RS485, CANopen □=E: EtherCAT		

FD1X5 servo driver technical parameters table



Model parameter		FD1X5 servo driver
		FD165-AB-000
Input	Power	Rated 96V(Support 72VDC~110VDC input)
	Logic power	Rated 24V/3A
Output	Maximum continuous output current (rms)	65 Arms(Up to 40Arms without auxiliary cooling plate)
	Peak current (AP)	265 A
Motor Encoder		Tamagawa Protocol, Incremental
Second encoder		BISS, Nikon encoder protocol, Tamagawa Protocol, AB Incremental
Energy consumption brake		Need external brake resistance (depending on the operation condition, mainly used in rapid start-stop occasions)
Energy consumption brake voltage absorption point		Default 105V
Overvoltage alarm voltage		Default 115V
Undervoltage alarm voltage		Default 72V
Cooling mode		Natural cooling Note:The output current for the FD165 is 65Arms,which is measured with the drive mounted on a 400mm*400mm*10mm (L*W*H) black oxide 6063 aluminum plate auxiliary heatsink.
Logic loss power (mW)		4000
General function	Input specification	8 channel digital input, COMI terminal; High level: 12.5~30VDC; Low level: 0~5VDC;Maximum frequency: 1KHz; Input impedance: 5KΩ.
	Input function	Freely defined as required, the functions are as follows: drive enable, drive error reset, drive mode control, speed loop proportional control, positive limit, negative limit, origin signal, command reverse, internal speed segment control, internal position segment control, emergency stop, start to find the origin, command activation, electronic gear ratio switching, gain switching
	Output specification	4 channel digital output,open collector output,maximum voltage 30V, 100mA drive capability
	Output function	Freely defined according to needs, the functions are as follows: driver ready, driver error, motor position to, motor zero speed, motor lock brake, motor speed reach, index Z signal appears, maximum limit speed in torque mode, motor lock shaft, motor limit medium, origin finding
	Pulse input	Pulse + Direction, A phase + B phase (12V~24V)
	Brake	Brake interface BR+/BR-, the voltage effective value is 24V, the output capacity is 2A, no external power supply required , can be directly drive the brake device
	Protect function	Overvoltage protection, undervoltage protection, motor overheat (I ² T) protection, short circuit protection, drive overheat protection
	Analog input	Dual input, can achieve analog control speed and torque, input range -10 ~10V
	Encoder output	5V motor A, B, Z signal, frequency division output range 0 ~ 65536; For multi-axis synchronization, the maximum output frequency is 5MHz
	Type-C	Debug special, can use Kinco PC software connection
Bus function	RS485	It supports a maximum 115.2K baud rate and can communicate with the controller using Modbus RTU
	CANopen	It supports a maximum of 1 M baud rate and can communicate with the controller using the CANopen
Installation site		Dust-free, dry, lockable (e.g. electrical cabinet)
Installation method		Install vertically or horizontally
Environment	Working Temperature	-20°C~40°C
	Storage temperature	-20°C~70°C
	Humidity (no condensation)	10%-95%RH
	Protection class	IP20
	Altitude	The rated working altitude is less than 1000 meters above sea level. When the working altitude is higher than 1000 meters, it is necessary to reduce the rated value by 1.5% for every 100 meters of elevation. The maximum working altitude is 2000 meters above sea level.
	Atmospheric pressure	86kpa~106kpa

FD125 mechanical dimension drawing

Note1: wiring is needed around the driver, so it is recommended to keep a space of > 80 mm.
 Note2: FD125-EB-000 has no dip switch

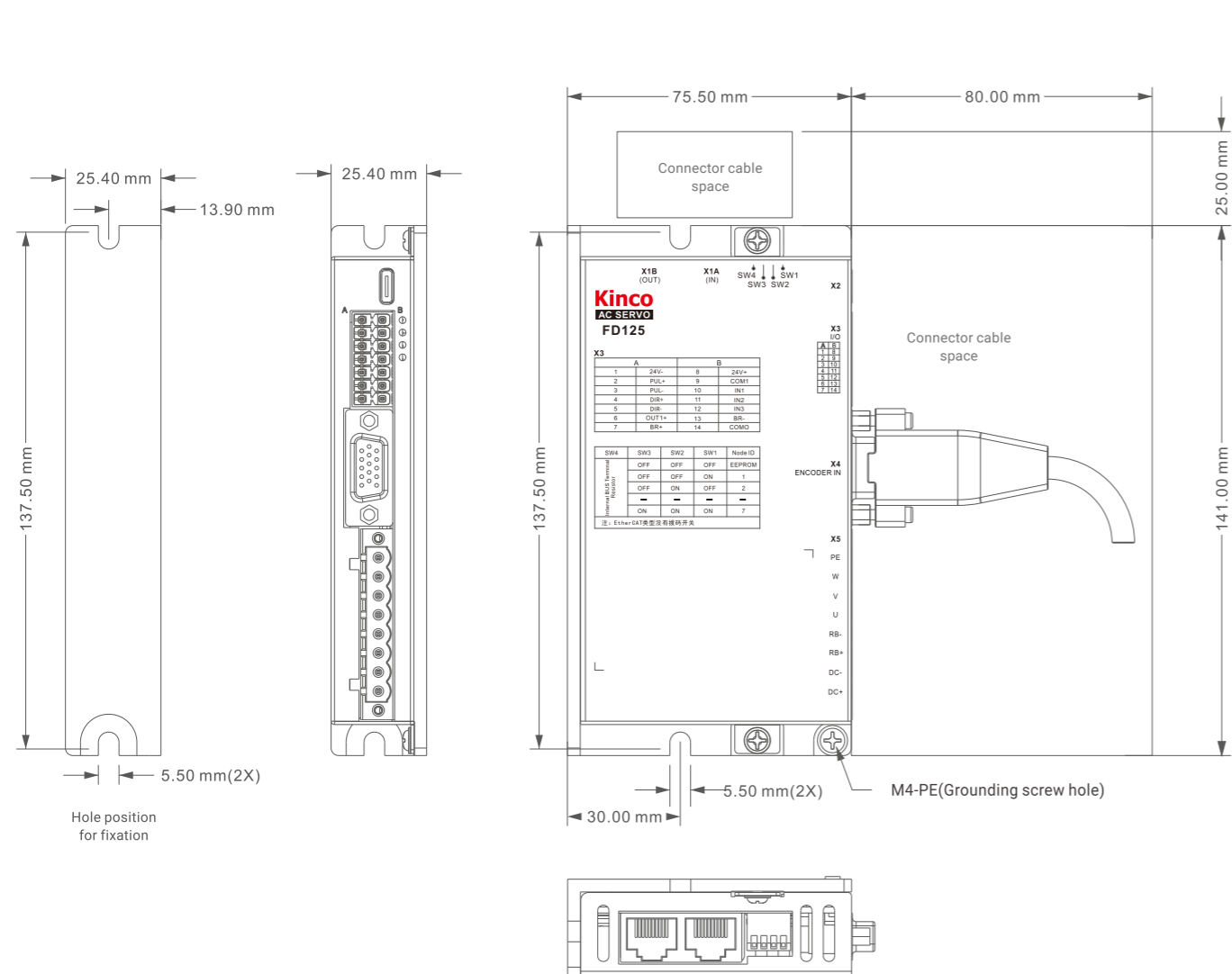

FD135 mechanical dimension drawing

Note1: wiring is needed around the driver, so it is recommended to keep a space of > 80 mm.
 Note2: FD135-EB-000 has no dip switch

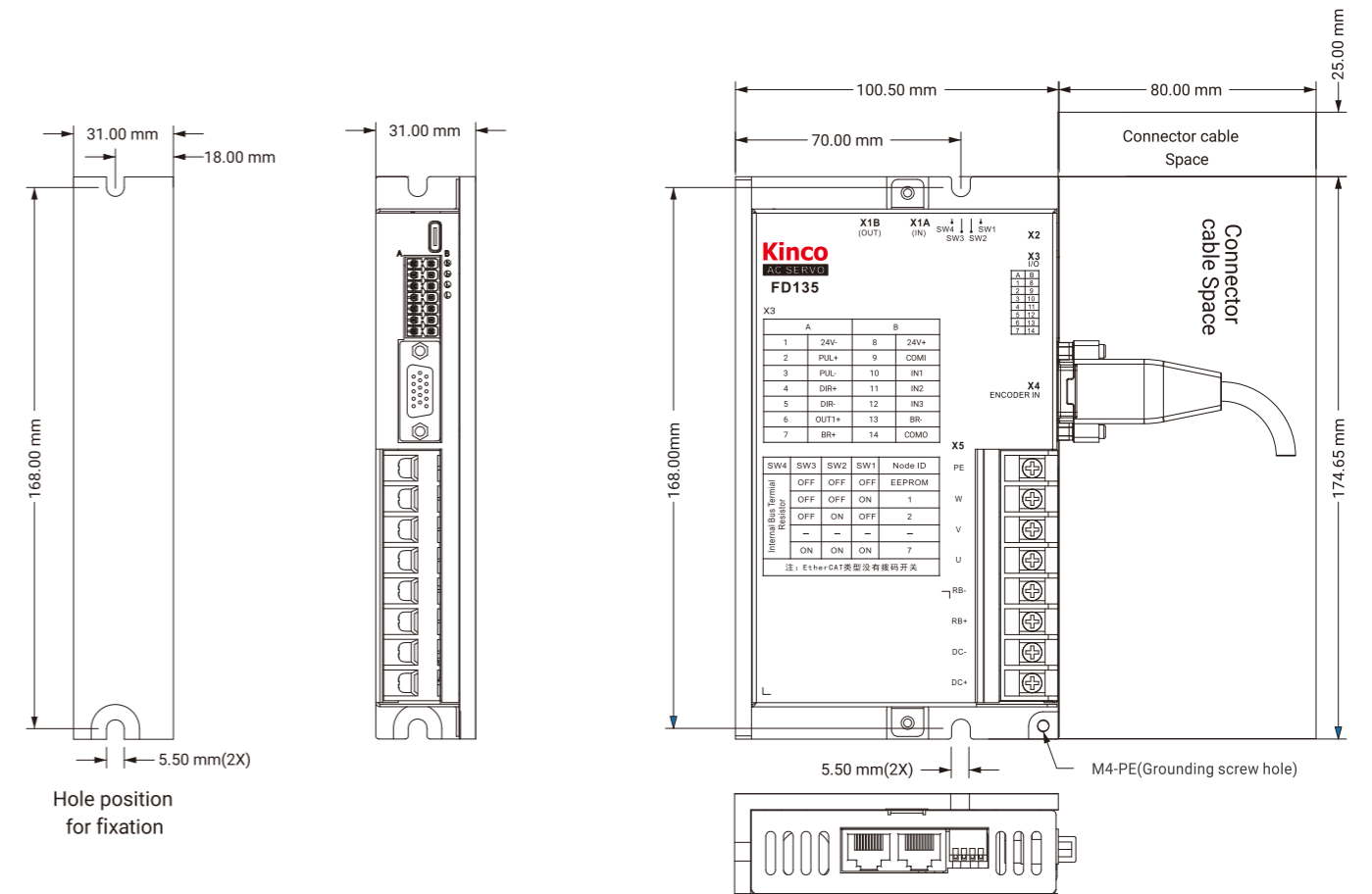

FD145 mechanical dimension drawing

Note1: wiring is needed around the driver, so it is recommended to keep a space of > 80 mm.
 Note2: FD145-EB-000 has no dip switch

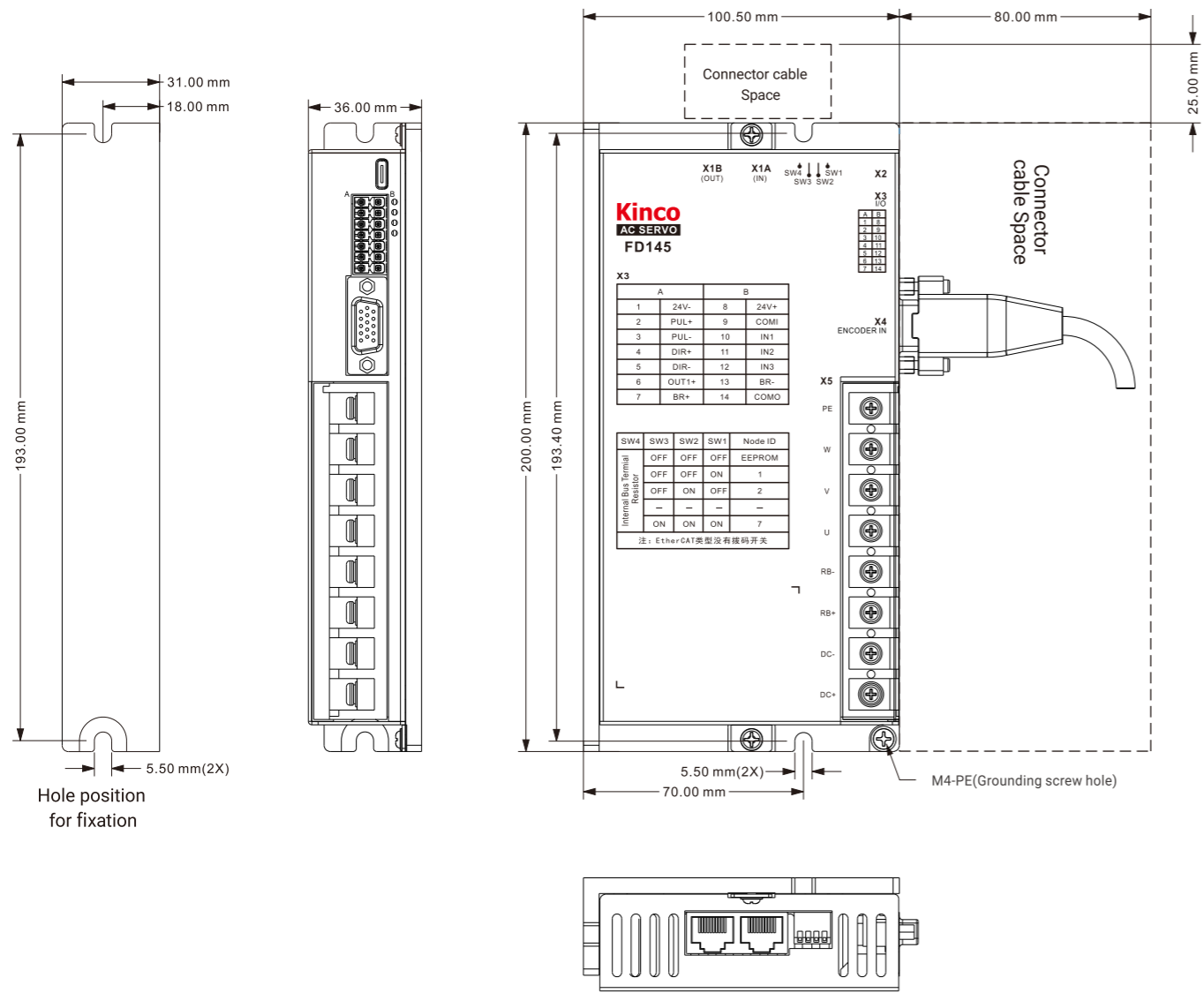

FD165 mechanical dimension drawing

Note: wiring is needed around the driver, so it is recommended to keep a space of > 80 mm

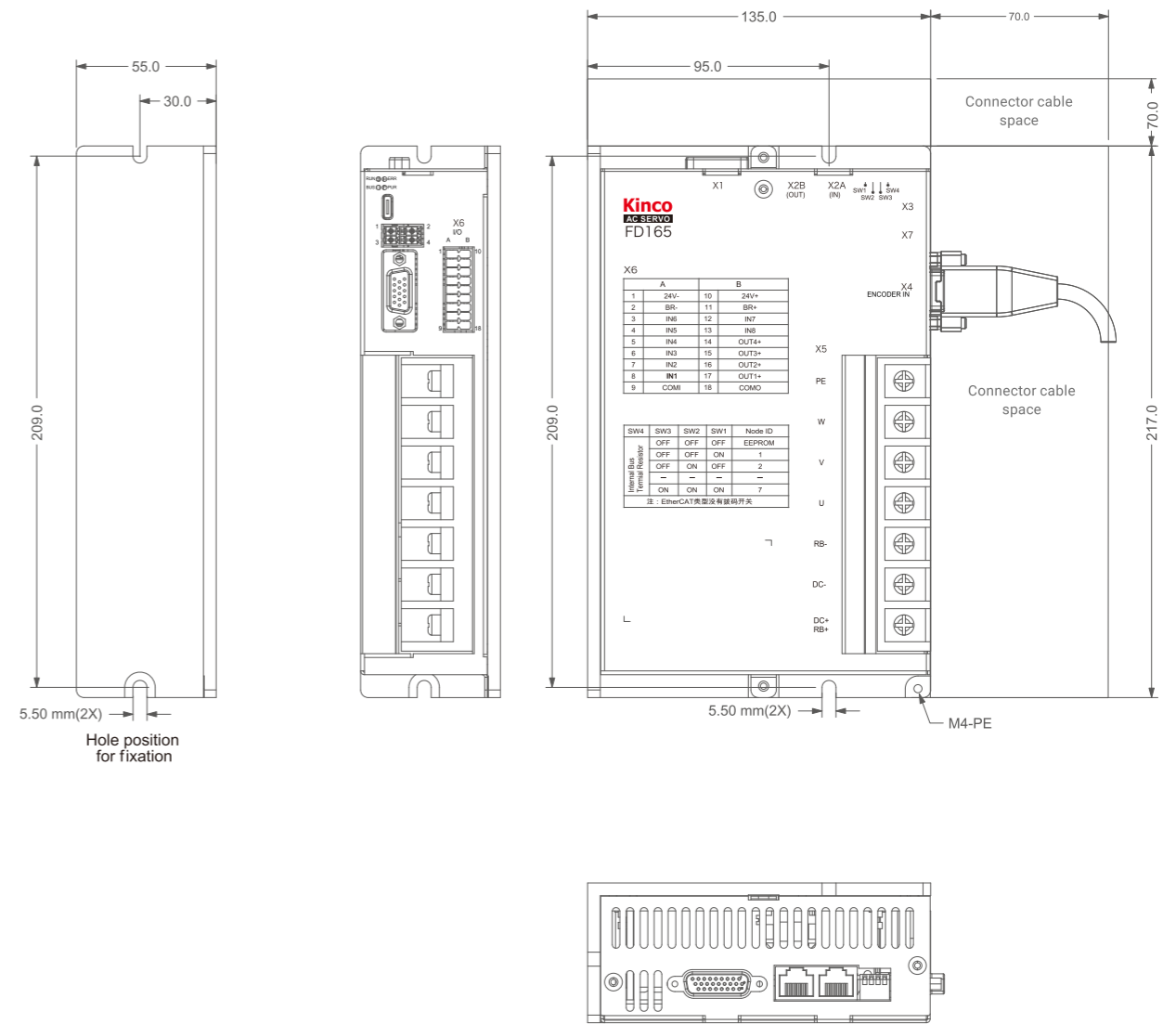

FD125/135/145 servo driver wiring port description

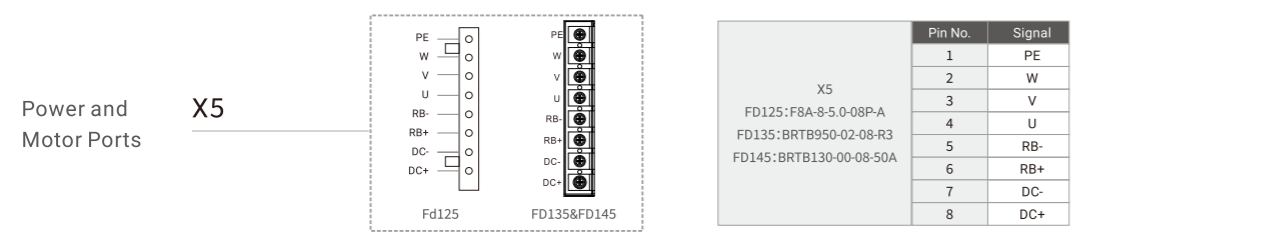
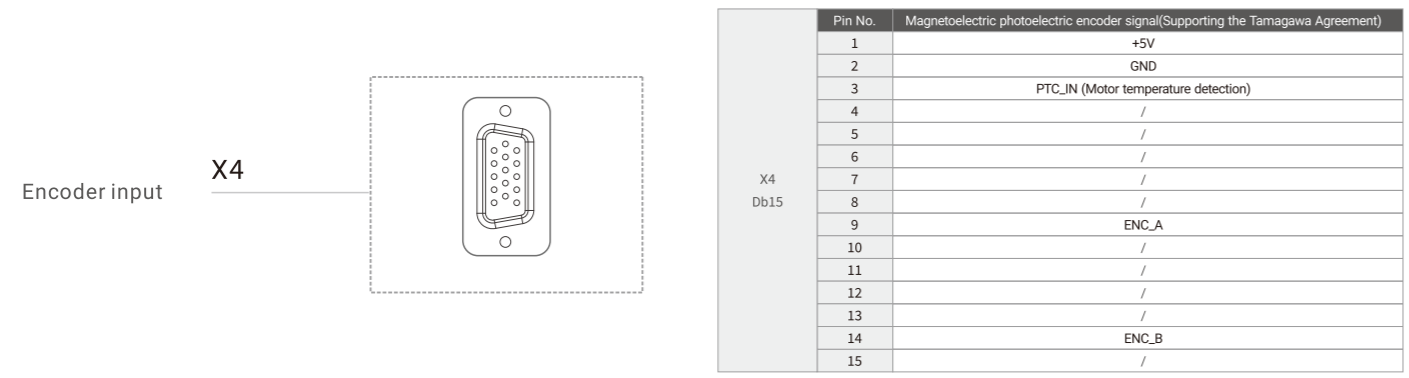
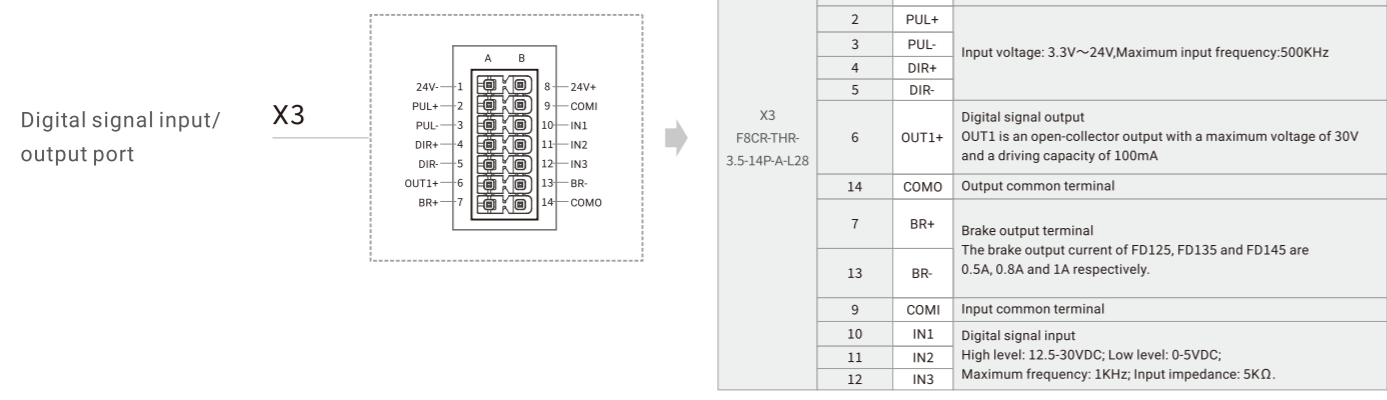
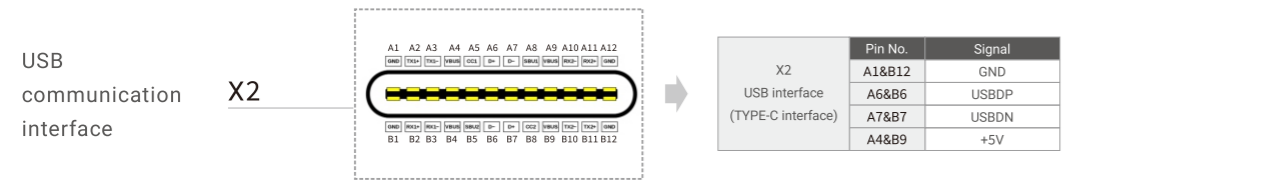
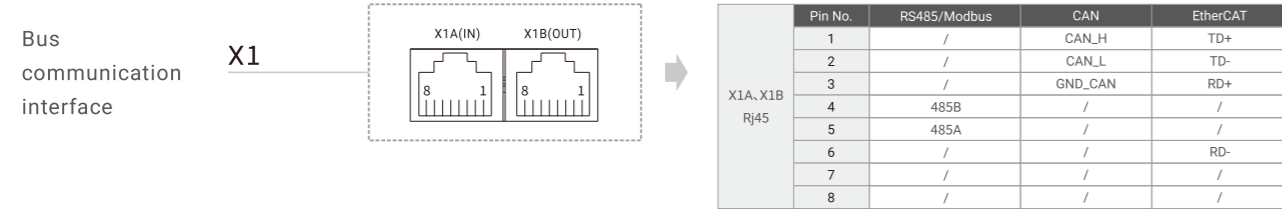

FD125/135/145 driver electrical wiring

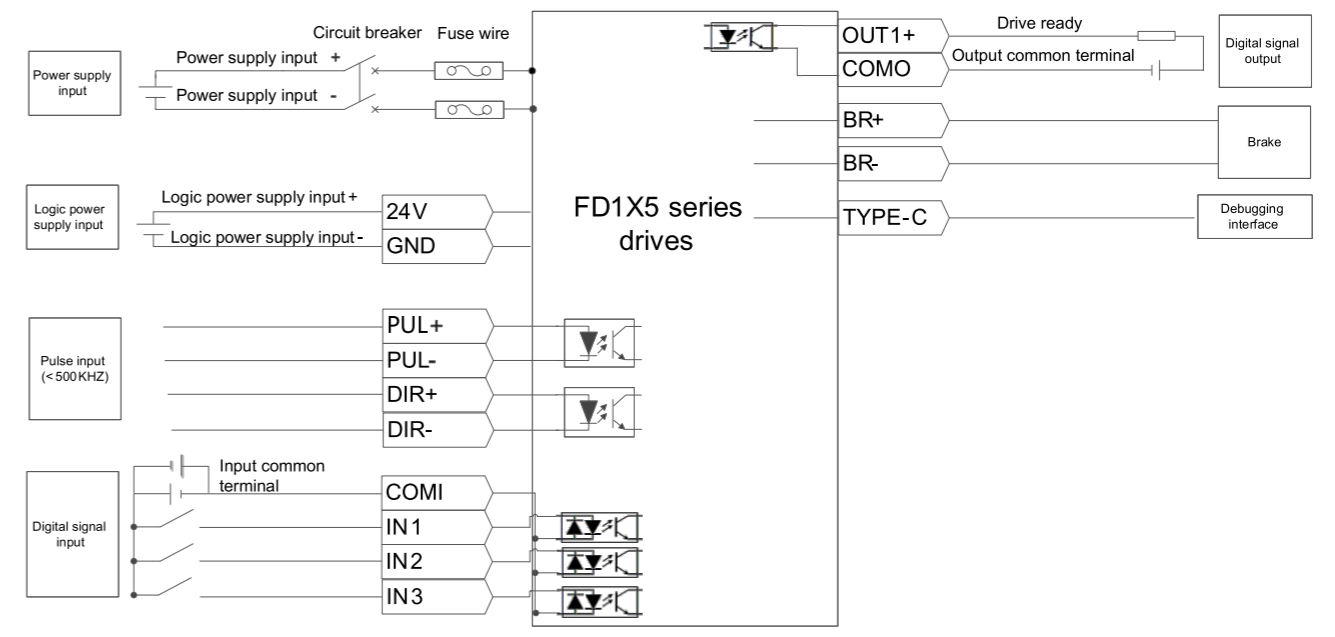

FD165 servo driver wiring port description

X1 DB26 Control signal interface

Pin No.	Signal	BISS Protocol	Tamagawa/Nikon Agreement	incremental
1	+5V		Second encoder 5V power positive	
2	MA_N-	MA_N-	/	/
3	MA_P+	MA_P+	/	/
4	/SD/SLO_N-	SLO_N-	/SD	/
5	SD/SLO_P+	SLO_P+	SD	/
6	MASTER_A	/	/	SECOND ENCODER A-
7	MASTER_A	/	/	SECOND ENCODER A+
8	MASTER_B	/	/	SECOND ENCODER B-
9	MASTER_B	/	/	SECOND ENCODER B+
10	GND		Second encoder 5V power supply negative	
11	ENCOUT_A		Encoder output A-	
12	ENCOUT_A		Encoder output A+	
13	ENCOUT_B		Encoder output B-	
14	ENCOUT_B		Encoder output B+	
15	ENCOUT_Z		Encoder output Z-	
16	ENCOUT_Z		Encoder output Z+	
17	GND		Internal 5V power supply output	
18	+5V_O			
19	AIN1-		Analog input 1-	
20	AIN1+		Analog input 1+	
21	AIN2-		Analog input 2-	
22	AIN2+		Analog input 2+	
23	PUL-		Pulse Input terminal	
24	PUL+		Input Voltage: 12V~24V	
25	DIR-		Maximum Input Frequency: 500K	
26	DIR+			

X2, X2B RJ45 Bus communication interface

Pin No.	RS485/Modbus	CAN
1	/	CAN_H
2	/	CAN_L
3	/	GND_CAN
4	485B	/
5	485A	/
6	/	/
7	/	/
8	/	/

X3 TYPE-C USB communication interface

Pin No.	RS485/Modbus
A1&B12	GND
A6&B6	USBDP
A7&B7	USBDN
A4&B9	+5V

X4 DB15 Encoder input

Pin No.	incremental	Magnetolectric photoelectric encoder signal (Supporting the Tamagawa Agreement)
1	+5V	+5V
2	GND	GND
3	/	/
4	U	/
5	/U	/
6	Z	/
7	B	/
8	A	/
9	W	ENC_A
10	V	/
11	/Z	/
12	/B	/
13	/A	/
14	/W	ENC_B
15	/V	/

X5 BA8-07-16.0-01-C Power and Motor Ports

Pin No.	Signal	Description
1	PE	
2	W	Servo motor power output terminal and motor grounding terminal
3	V	
4	U	
5	RB-	Braking resistor -
6	DC-	Power input -
7	DC+/RB+	Power input +/Braking resistor +

X6 F8CR-THR-3.5-18P-A-L28 Digital signal input/output port

Pin No.	Signal	Description
1	24V-	Logic power input -; Input voltage: 24V, Rated input current: 3A
10	24V+	Logic power input +; Input voltage: 24V, Rated input current: 3A
2	BR-	Brake output -; The brake port output current is 2A.
11	BR+	Brake output +; The brake port output current is 2A.
3	IN6	Digital signal input terminal High level: 12.5-30VDC; Low level: 0-5VDC; Maximum frequency: 1KHz; Input impedance: 5KΩ.
4	IN5	
5	IN4	
6	IN3	
7	IN2	
8	IN1	
12	IN7	
13	IN8	
9	COMI	Input common terminal
14	OUT4+	Digital signal output
15	OUT3+	
16	OUT2+	
17	OUT1+	
18	COMO	Output common terminal

X7 (RESERVE)

FD165 servo driver electrical wiring

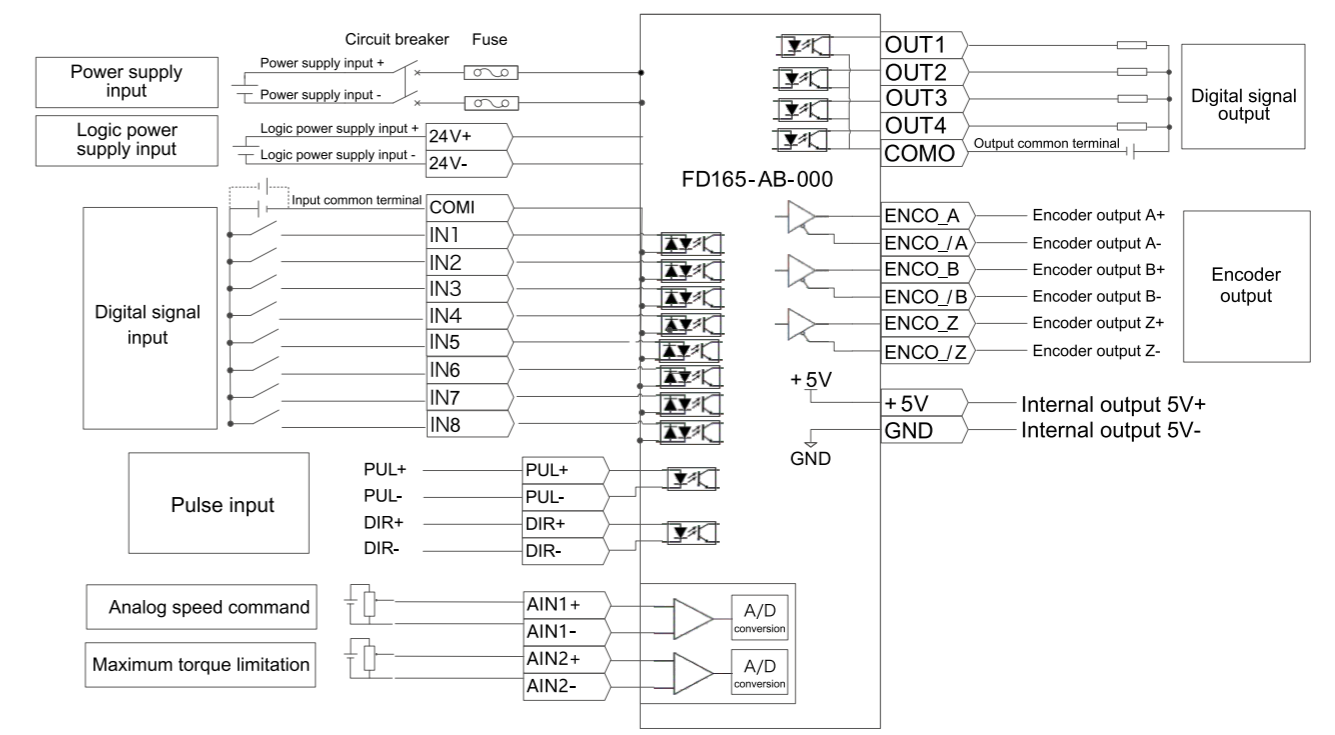

Low-voltage servo motor

Product features:

New electromagnetic design

Adopting 12-slot and 10-pole design, with small slot torque and low torque pulsation, which is conducive to reducing the vibration during the operation of the motor and making the torque output more smooth.

New structure and short fuselage

The redesign of the fuselage structure shortens the length of the fuselage, which can save more installation space and reduce the size of the equipment for customers' equipment.

Insulation class F

The motor in the industry is at the highest insulation level, which can maintain high reliability and stability in high temperature extreme environment.

Energy efficiency class: 2



Servo motor naming rules

Model: **SMK60S-0040-30SAK-5DSA**

① ② ③ ④ ⑤ ⑥ ⑦ ⑧ ⑨ ⑩ ⑪ ⑫

①-Series name	SMK:Common body series SMC:SMCseries	⑦-Brake	A:Without brake B:With brake
②-Flange	60:60x60(mm) 80:80x80(mm) 180:180x180(mm)	⑧-Output axis style	K:Withkey
③-Inertia type	S:Small inertia G:High inertia	⑨-Number of polar pairs	4:4-pole pair 5:5-pole pair
④-Rated power	0020:10x20(W) 0040:10x40(W) 0075:10x75(W) 0500:10x500(W)	⑩- Supply voltage	D:DC48V G:DC96V
⑤-Rated speed	20:20x100(rpm) 30:30x100(rpm)	⑪- Motor version number	S:S version K:K version
⑥-Encoder type	S:Singleturn communication type magnetoelectric encoder Q: Multiturn communication type magnetoelectric absolute encoder	⑫- Motor Outlet Type	A: Special socketfor common body motor U: Communication encoder socket H: Three-row 15-pin encoder socket

Note: The oil seal is an optional accessory, and it can be omitted if it is not necessary.

SMK series servo motor technical parameters table

Servo motor model	SMK series servo motor			
	SMK60S-0020-30□■K-5DSA	SMK60S-0040-30□■K-5DSA	SMK80S-0075-30□■K-5DKA	SMK80S-0100-30□■K-5DKA
Drive power supply voltage	48	48	48	48
Intermediate link DC voltage VDC				
Continuous Characteristics	Rated power Pn(W)	200	400	750
	Rated torque Tn(Nm)	0.64	1.27	2.39
	Rated speed Nn (rpm)	3000	3000	3000
	Rated current In(A)	5.7	10.6	19.2
Max torqueTm(Nm)	1.92	3.81	7.17	9.54
Max current Im (A)	18.2	33.9	62.7	81
Max speed (rpm)	4300	4000	3900	3960
Standstill torque Ts(Nm)	0.7	1.4	2.63	3.5
Standstill current Is(A)	6.27	11.7	21.1	28.4
Torque constant Kt (Nm/A)	0.124	0.132	0.137	0.136
Rotor moment of inertia Jm (Kg·cm ²)	0.17	0.31	0.85	1.16
	0.174(with brake)	0.314(with brake)	0.91(with brake)	1.22(with brake)
Brake	Brake holding torque (Nm)	2	2	4
	Rated power (W)	7.6	7.6	11.5
	Rated voltage (VDC)	24	24	24
Insulation class	F	F	F	F
Max radial force Fr(N)	40	40	392	392
Max axial force Fa(N)	30	30	147	147
Cooling method	Totally enclosed, self-cooling			
Protection level	IP65, IP54 at the shaft end			
Operation environment	Temperature	- 20~40°C		
	Humidity	Below 90% RH (no condensation)		
	Ambient environment	Keep away from corrosion, flammable gases, oil droplets, dust		
	Altitude	The highest altitude is 2000m. From 1000 to 2000m, the power decreases by 1.5% per 100m increase		

Note: □ = S : Singleturn communication type magnetoelectric encoder ■ = A : Without brake
 Q : Multiturn communication type magnetoelectric absolute encoder B : With brake

SMK series servo motor technical parameters table

Servo motor model	SMK series servo motor			
	SMK180G-0300-20Q ■ K-4GSH	SMK180G-0400-20Q ■ K-4GSH	SMK180G-0500-20Q ■ K-4GSH	
Drive power supply voltage	96	96	96	
Intermediate link DC voltage VDC				
Continuous Characteristics	Rated power Pn(W)	3000	4000	5000
	Rated torque Tn(Nm)	14.33	19.1	23.88
	Rated speed Nn (rpm)	2000	2000	2000
	Rated current In(A)	37.5	50	62.5
Max torque Tm(Nm)	43	57.3	59.7	
Max current Im (A)	120	160	156	
Max speed (rpm)	2631	2425	2631	
Standstill torque Ts(Nm)	15.76	21	26.27	
Standstill current Is(A)	41.3	55	65.75	
Torque constant Kt (Nm/A)	0.43	0.42	0.42	
Rotor moment of inertia Jm (Kg·cm ²)	47.34	62.34	81	
	51.43(with brake)	66.43(with brake)	85.09(with brake)	
Brake	Brake holding torque (Nm)	55	55	55
	Rated power (W)	36	36	36
	Rated voltage (VDC)	24	24	24
Insulation class	F	F	F	
Max radial force Fr(N)	1470	1470	1470	
Max axial force Fa(N)	490	490	490	
Cooling method	Totally enclosed, self-cooling			
Protection level	IP54			
Operation environment	Temperature	-20~40°C		
	Humidity	Below 90% RH (no condensation)		
	Ambient environment	Keep away from corrosion, flammable gases, oil droplets, dust		
	Altitude	The highest altitude is 2000m. From 1000 to 2000m, the power decreases by 1.5% per 100m increase		

Note: □ = S : Singleturn communication type magnetoelectric encoder
Q : Multiturn communication type magnetoelectric absolute encoder

■ = A : Without brake
B : With brake

SMC series servo motor technical parameters table

Servo motor model	SMC series servo motor			
	SMC60S-0060-30Q ■ K-5DSU	SMC80S-0120-30Q ■ K-5DSU	SMC80S-0150-30Q ■ K-5DSU	
Drive power supply voltage	48	48	48	
Intermediate link DC voltage VDC				
Continuous Characteristics	Rated power Pn(W)	600	1200	1500
	Rated torque Tn(Nm)	1.91	3.82	4.77
	Rated speed Nn (rpm)	3000	3000	3000
	Rated current In(A)	16.5	34	37.4
Max torque Tm(Nm)	5.73	11.5	14.31	
Max current Im (A)	52.8	107.1	112.2	
Max speed (rpm)	4000	4000	3400	
Standstill torque Ts(Nm)	2.1	4.2	5.247	
Standstill current Is(A)	18.1	37.4	41.14	
Torque constant Kt (Nm/A)	0.124	0.127	0.14	
Rotor moment of inertia Jm (Kg·cm ²)	0.65	1.36	1.64	
	0.654 (带抱闸)	1.41 (带抱闸)	1.901 (带抱闸)	
Brake	Brake holding torque (Nm)	2	4	5
	Rated power (W)	7.6	11.5	11.5
	Rated voltage (VDC)	24	24	24
Insulation class	F	F	F	
Max radial force Fr(N)	180	335	335	
Max axial force Fa(N)	90	167.5	167.5	
Cooling method	Totally enclosed, self-cooling			
Protection level	IP54			
Operation environment	Temperature	- 20~40°C		
	Humidity	Below 90% RH (no condensation)		
	Ambient environment	Keep away from corrosion, flammable gases, oil droplets, dust		
	Altitude	The highest altitude is 2000m. From 1000 to 2000m, the power decreases by 1.5% per 100m increase		

Note: ■ = A : Without brake
B : With brake

SMK series servo motor dimensions

60 flange

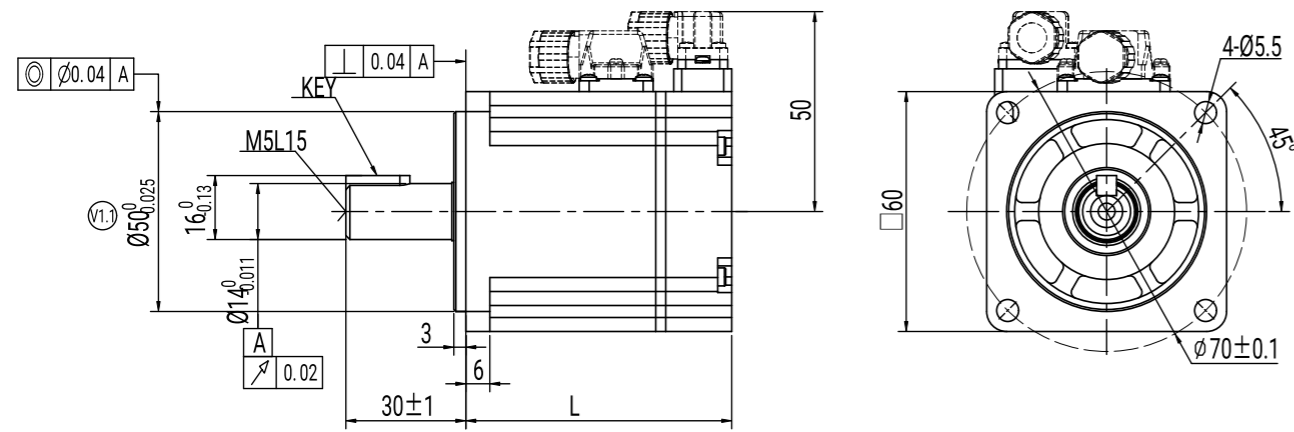

60 flange (with brake)

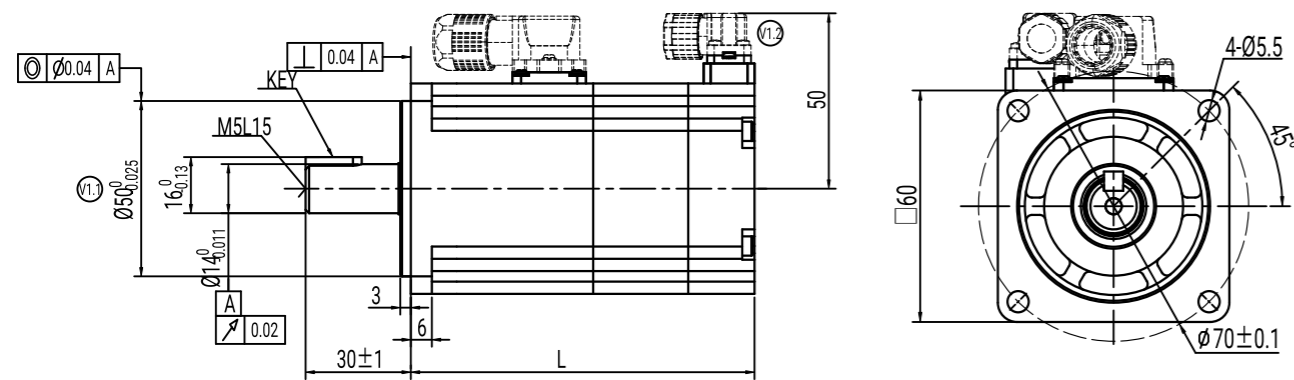

SMK series servo motor dimensions

80 flange

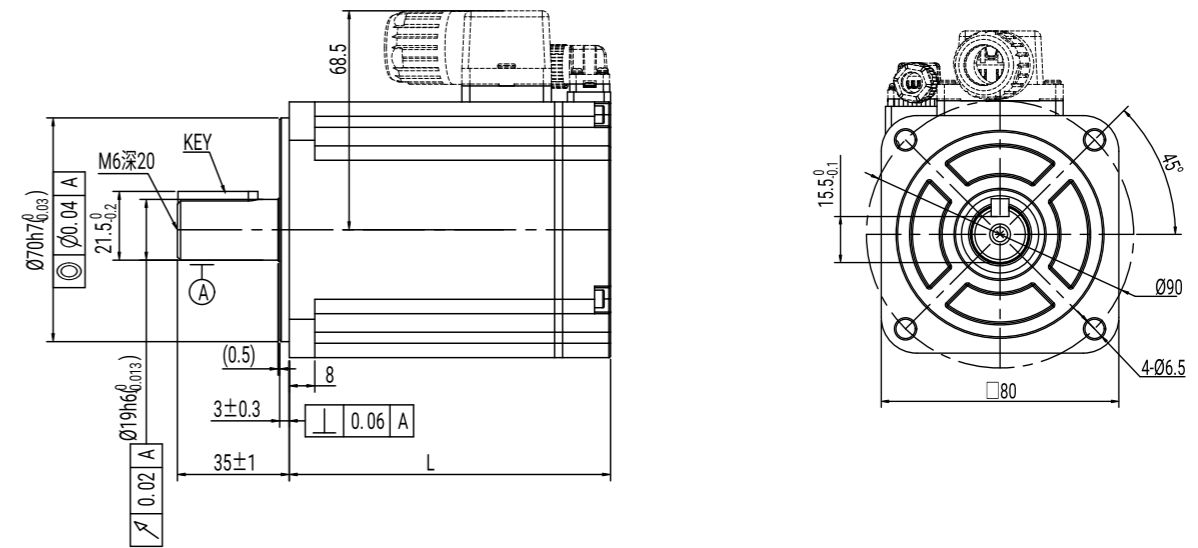

80 flange (with brake)

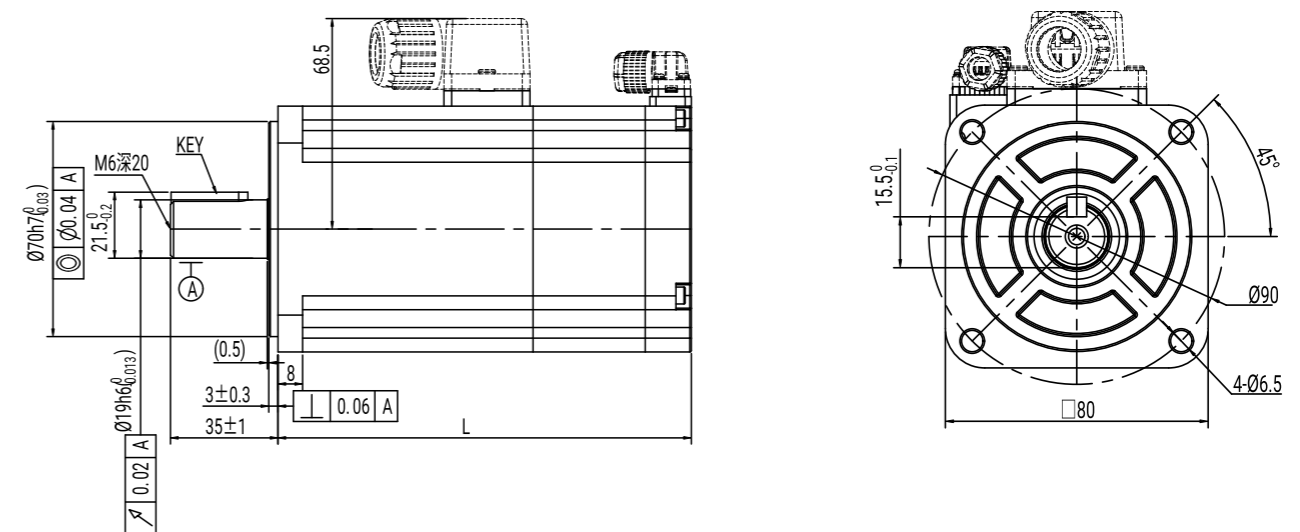

SMK60 series models	With brake	Weight (KG)	Motor body size L (mm)
SMK60S-0020-30SAK-5DSA		0.9	66.5 ± 1.5
SMK60S-0020-30QAK-5DSA			
SMK60S-0020-30SBK-5DSA	✓	1.3	98 ± 1.5
SMK60S-0020-30QBK-5DSA			
SMK60S-0040-30SAK-5DSA		1.1	89 ± 1.5
SMK60S-0040-30QAK-5DSA			
SMK60S-0040-30SBK-5DSA	✓	1.5	116 ± 1.5
SMK60S-0040-30QBK-5DSA			

SMK80 series models	With brake	Weight (KG)	Motor body size L (mm)
SMK80S-0075-30SAK-5DKA		1.9	100.5 ± 1
SMK80S-0075-30QAK-5DKA			
SMK80S-0075-30SBK-5DKA	✓	2.6	134.5 ± 1
SMK80S-0075-30QBK-5DKA			
SMK80S-0100-30SAK-5DKA		2.4	112.5 ± 1
SMK80S-0100-30QAK-5DKA			
SMK80S-0100-30SBK-5DKA	✓	3.1	146.5 ± 1
SMK80S-0100-30QBK-5DKA			

SMK series servo motor dimensions

180 flange

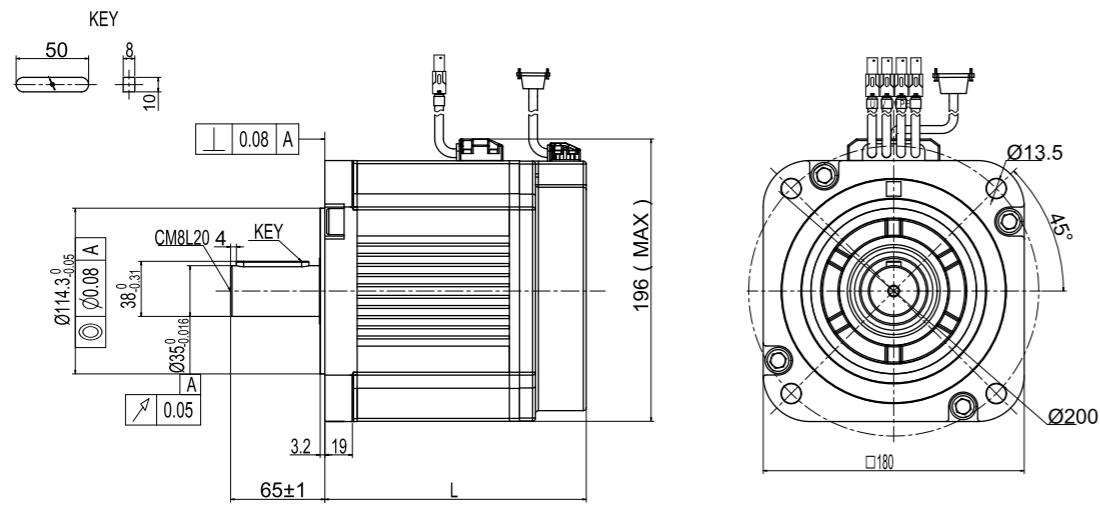

180 flange (with brake)

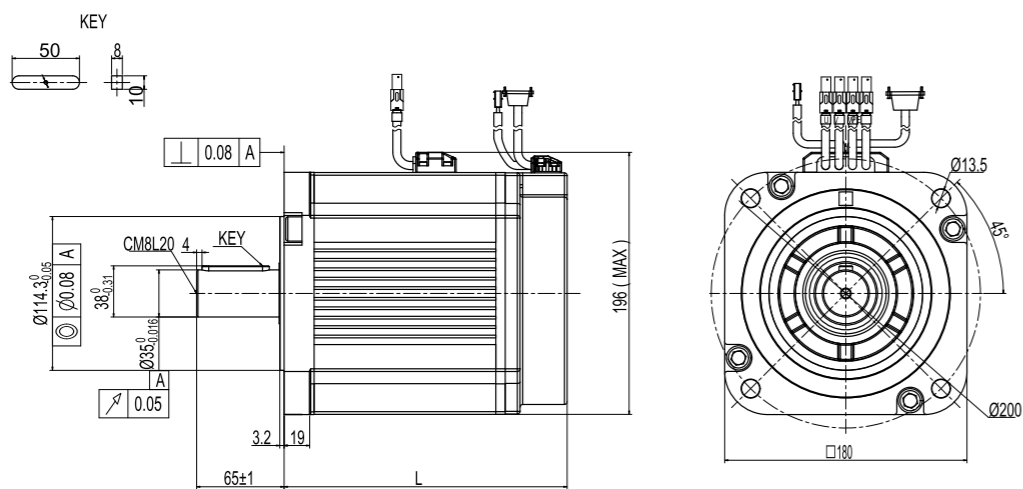

SMK180 series models	With brake	Weight (KG)	Motor body size L (mm)
SMK180G-0300-20QAK-4GSH		14.6	180.5±1
SMK180G-0300-20QBK-4GSH	√	18.4	210.5±1
SMK180G-0400-20QAK-4GSH		17.2	195.5±1
SMK180G-0400-20QBK-4GSH	√	21	225.5±1
SMK180G-0500-20QAK-4GSH		21.8	215.5±1
SMK180G-0500-20QBK-4GSH	√	25.6	245.5±1

SMK series servo motor end connectors and wiring

Num	Definition
1	U
2	W
3	V
4	PE

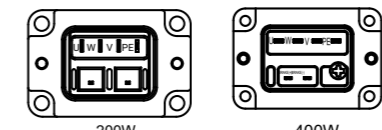

SMK60 power socket without brake

Num	Definition
1	U
2	W
3	V
4	PE

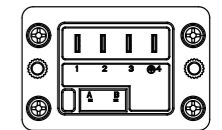

SMK80 power socket without brake

Num	Definition
1	U
2	W
3	V
4	PE
5	BR+
6	BR-

SMK60 power socket with brake

Num	Definition
1	U
2	W
3	V
4	PE
5	BR+
6	BR-

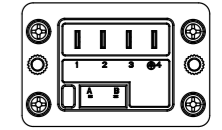

SMK80 power socket with brake

Num	Single-turn encoder definition	Multi-turn encoder definition
1	+5V	+5V
2	GND	GND
3	/	VB+
4	/	VB-
5	SD+	SD+
6	SD-	SD-

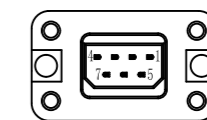

SMK60&80 encoder socket

SMK series servo motor curve

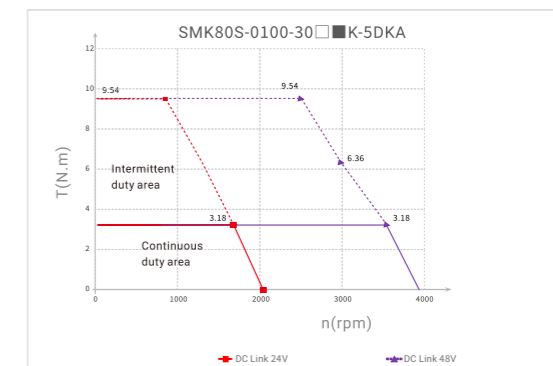
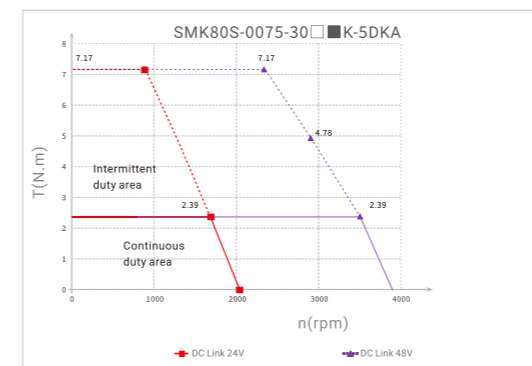
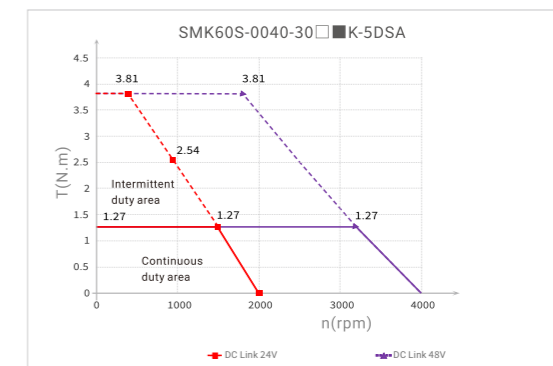
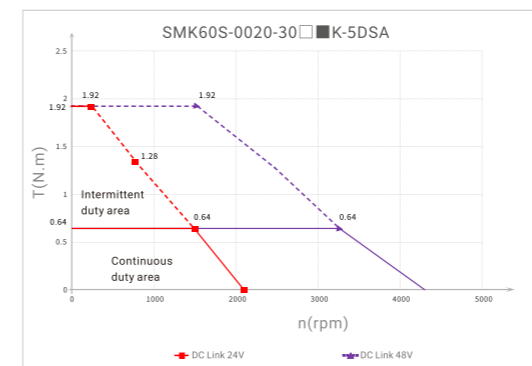

SMK series servo motor curve

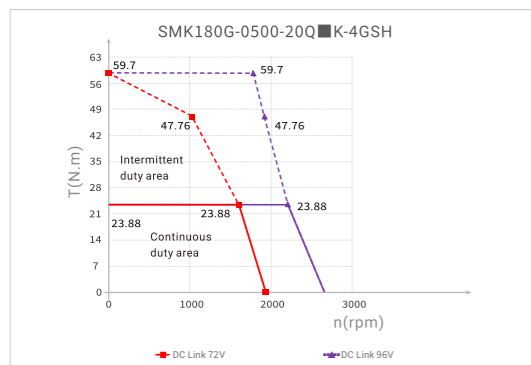
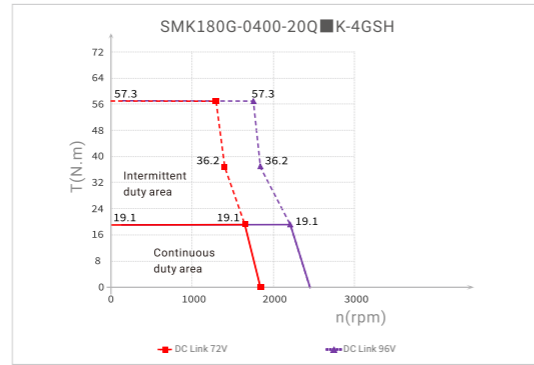
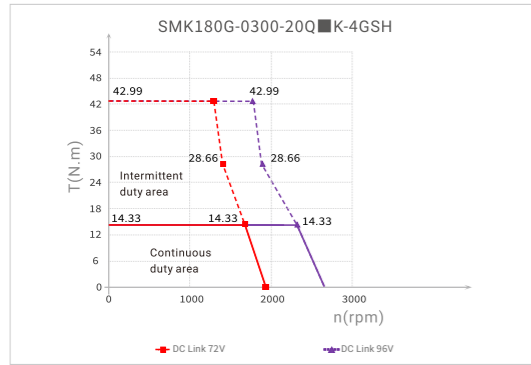

SMC series servo motor dimensions

60 flange (with brake)

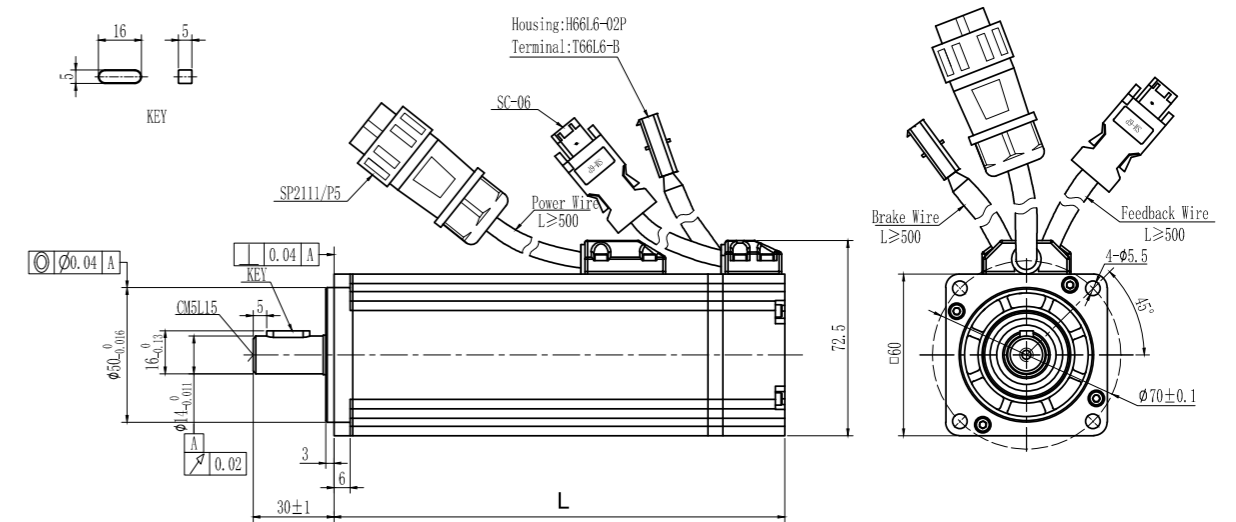

SMC60 series models	With brake	Weight (KG)	Motor body size L (mm)
SMC60S-0060-30QAK-5DSU		1.9	132.5 ± 1.5
SMC60S-0060-30QBK-5DSU	√	2.3	167.5 ± 1.5

SMC series servo motor dimensions

60 flange

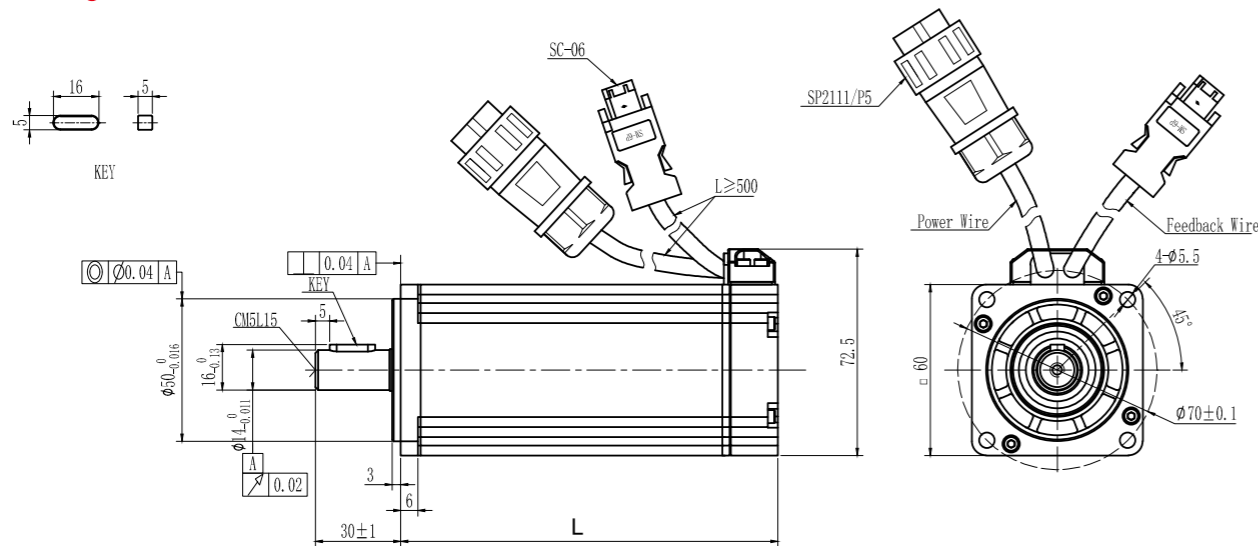

80 flange

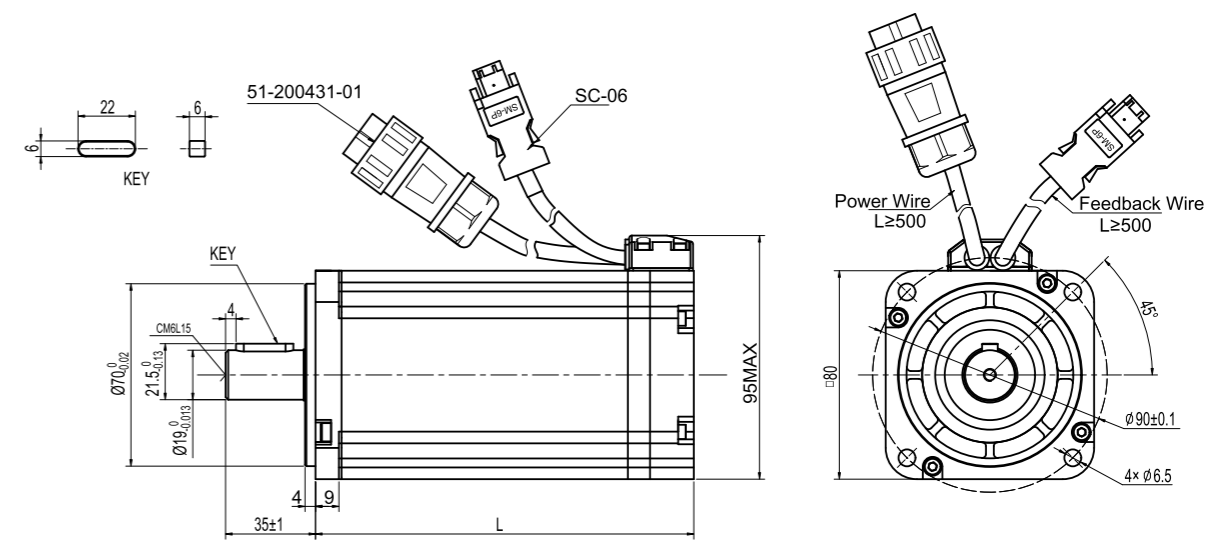

SMC series servo motor dimensions

80 flange (with brake)

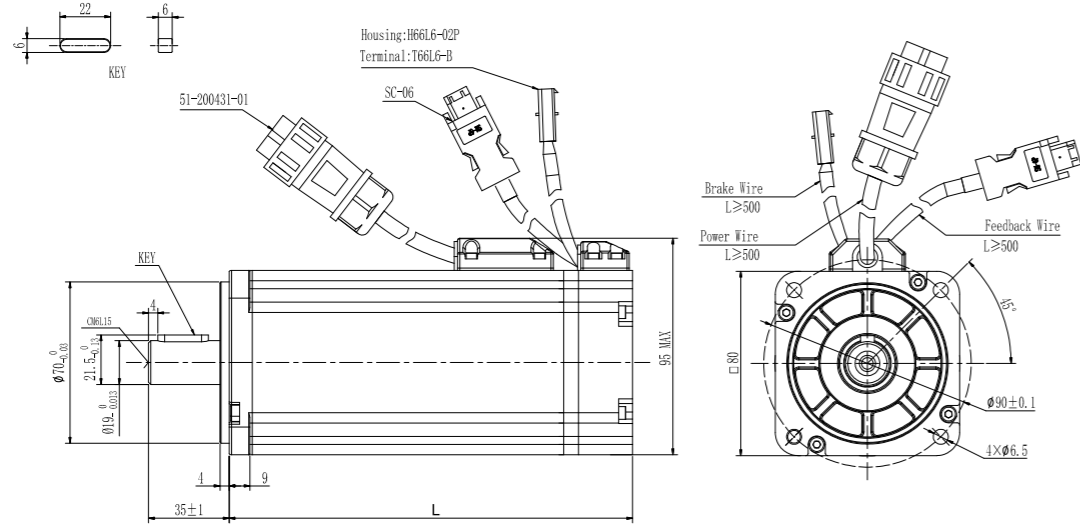

SMC60 series models	With brake	Weight (KG)	Motor body size L (mm)
SMC80S-0120-30QAK-5DSU		3	122.7±1.5
SMC80S-0120-30QBK-5DSU	√	3.3	157±1.5
SMC80S-0150-30QAK-5DSU		3.9	145.2±1.5
SMC80S-0150-30QBK-5DSU	√	4.2	175±1.5

SMC series servo motor curve

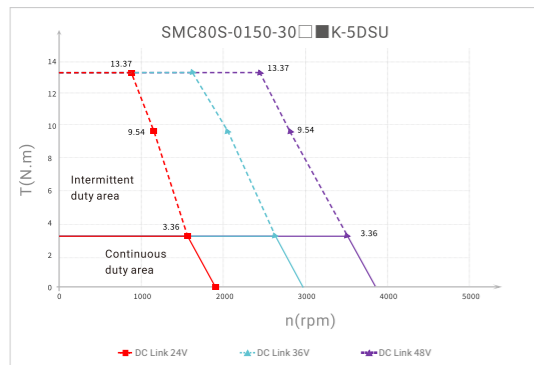
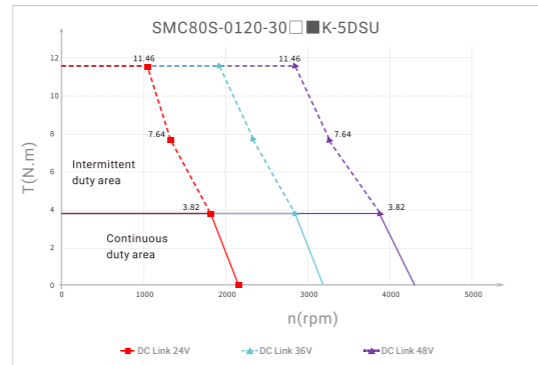
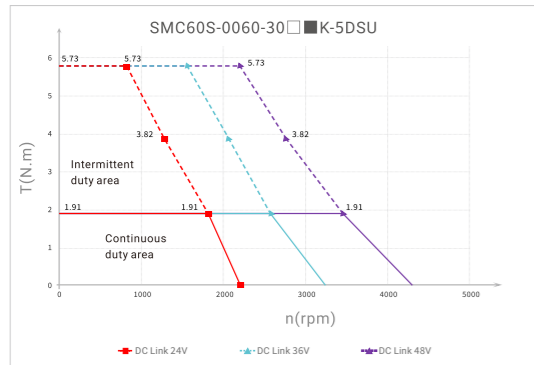

Cable naming rules

Power cable

MOT F - 005 - LL - KAB - D

① ② ③ ④ ⑤ ⑥

①-Cable function type	MOT: Motor power cable	④ -Cable length	(5) :0.5m 01:1m 02:2m 03:3m
②-Cable type	F: Flexible cable empty: Common cable	⑤-Motor outlet type	KA: Pluggable motor connector (power) KAB: Pluggable motor connector (power and brake) LS: LCA series connector LJ51: JNICON 51series connector
③-Rated current	005: 5A 011: 11A 020: 20A 030: 30A 040: 40A 080: 80A	⑥-Connector types	D: Common body motor front outgoing DF: Common body motor rear outgoing

Encoder cable/encoder battery cable

ENC D G F - LL - G A - DC

① ② ③ ④ ⑤ ⑥ ⑦ ⑧

①-Cable function type	ENC: Motor encoder cable	⑤-Cable length	(5) :0.5m 01:1m 02:2m 03:3m
②-Drive encoder connector type	D: 1394 connector H: Three rows of 15DB connectors	⑥-Core cable type	G: 6-core cable
③-Drive connector definition	G: Communication type connector	⑦-Type of encoder connector to the motor end	A: Pluggable encoder connector U: 1394 connector H: Three-row DB15 connector
④-Cable type	F: Flexible cable Empty: Common cable	⑧-Cable accessories	DC: With battery box outlet wire F: Without battery, Common body motor rear outgoing Empty: Without battery, Common body motor front outgoing

Wiring drawing

ENCHG-LL-GA

Wire Specification: 1P*22AWG+2P*26AWG standard cable
 22AWG cross sectional area 0.3247mm²
 26AWG cross sectional area 0.1281mm²

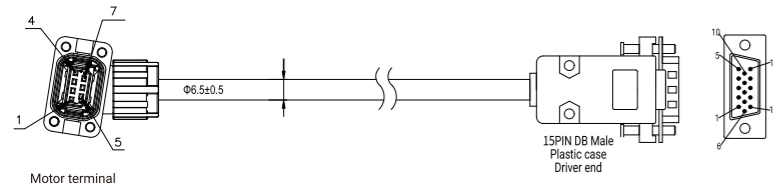

ENCHG-LL-GA			
Signal	Motor side	Color	Driver side 15PIN DB male
+5V	PIN1	red	PIN1
GND	PIN2	orange	PIN2
/	PIN3	/	/
/	PIN4	/	/
SD+	PIN5	blue	PIN9
SD-	PIN6	purple	PIN14
Shielding	PIN7	Shielding wire	Shielding

Corresponding accessory: ENCHG-GA
 Corresponding flexible cable: ENCHGF-LL-GA
 Wire spec: 1P*22AWG+2P*26AWG flexible drag chain cable
 Wire diameter: 6.5±0.5mm

ENCHG-LL-GA-F

Wire Specification: 1P*22AWG+2P*26AWG, standard cable
 22AWG cross sectional area 0.3247mm²
 26AWG cross sectional area 0.1281mm²

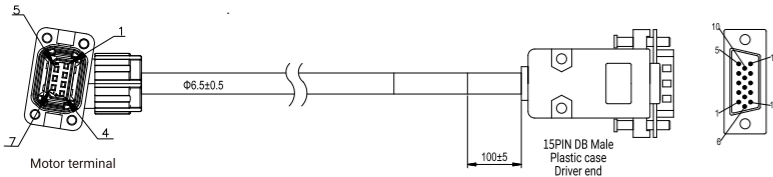

ENCHG-LL-GA-F			
Signal	Motor side	Color	Driver side 15PIN DB male
+5V	PIN1	red	PIN1
GND	PIN2	orange	PIN2
/	PIN3	/	/
/	PIN4	/	/
SD+	PIN5	blue	PIN9
SD-	PIN6	purple	PIN14
Shielding	PIN7	Shielding wire	Shielding

Corresponding accessory: ENCHG-GA-F

ENCDG-LL-GA

Wire Specification: 1P*22AWG+2P*26AWG standard cable
 22AWG cross sectional area 0.3247mm²
 26AWG cross sectional area 0.1281mm²

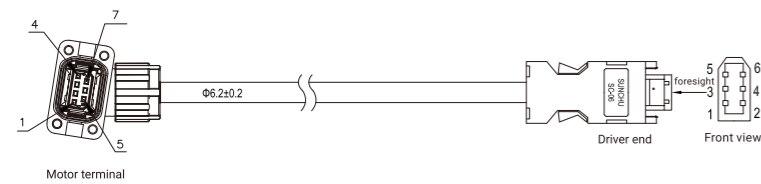

ENCDG-LL-GA			
Signal	Motor side	Color	Driver side SC06 male
+5V	PIN1	red	PIN1
GND	PIN2	orange	PIN2
/	PIN3	brown	PIN3
/	PIN4	black	PIN4
SD+	PIN5	blue	PIN5
SD-	PIN6	purple	PIN6
Shielding	PIN7	Shielding wire	Shell

Corresponding accessory: ENCDG/ENCDGF-GA
 Corresponding flexible cable: ENCDGF-LL-GA
 Wire spec: 1P*22AWG+2P*26AWG flexible drag chain cable
 Wire diameter: 6.2±0.2mm

Wiring drawing

ENCHG-(4)-GU-DC

Wire Specification: 3×2 × 0.2mm²

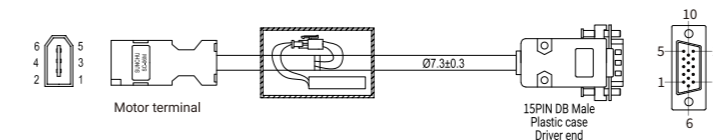

ENCHG-(4)-GU-DC					
Signal	Motor side SC-06 female	black HSG	Color	External single wire	Driver side 15PIN DBmale
+5V	PIN1	/	red	/	PIN1
GND	PIN2	/	black	/	PIN2
VB+	PIN3	PIN1	brown	red	/
VB-	PIN4	PIN2	blue	black	/
SD+	PIN5	/	yellow	/	PIN9
SD-	PIN6	/	green	/	PIN14
Shielding	Shell	/	Shielding wire	/	Shell

ENCDG-LL-GU

Wire Specification: 1P*20AWG+2P*24AWG standard cable
 20AWG cross sectional area 0.5189mm²
 24AWG cross sectional area 0.2047mm²



ENCDG-LL-GU			
Signal	Motor side	Color	Driver side SC06 male
+5V	PIN1	red	PIN1
GND	PIN2	black	PIN2
VB+	PIN3	brown	PIN3
VB-	PIN4	blue	PIN4
SD+	PIN5	yellow	PIN5
SD-	PIN6	green	PIN6
Shielding	Shell	Shielding wire	Shell

Corresponding accessory: ENCDG-GU
 Corresponding flexible cable: ENCDGF-LL-GU
 Wire spec: 1P*20AWG+2P*24AWG flexible drag chain cable
 Wire diameter: 6.5±0.5mm

ENCHG-(4)-GH-DC

Wire Specification: 3×2 × 0.2mm²

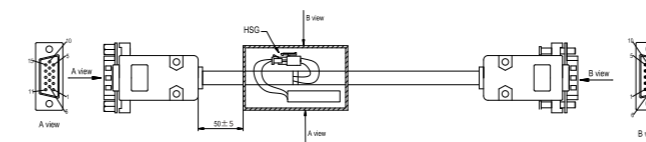

ENCHG-(4)-GH-DC					
Signal	Motor side 15PIN DB female	black HSG	Color	External single wire	Driver side 15PIN DB male
+5V	PIN1	/	red	/	PIN1
GND	PIN2	/	black	/	PIN2
VB+	PIN10	PIN1	brown	red	/
VB-	PIN15	PIN2	blue	black	/
SD+	PIN9	/	yellow	/	PIN9
SD-	PIN14	/	green	/	PIN14
Shielding	Shell	/	Shielding wire	/	Shell

ENCHG-LL-GH

Wire Specification: 1P*22AWG+2P*26AWG standard cable
 22AWG cross sectional area 0.3247mm²
 26AWG cross sectional area 0.1281mm²

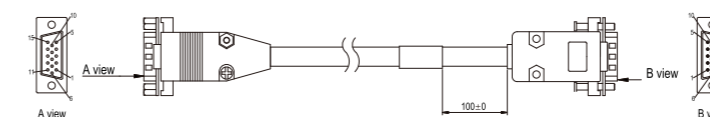

ENCHG-LL-GH			
Signal	Motor side 15PIN DB female	Color	Driver side 15PIN DB male
+5V	PIN1	red	PIN1
GND	PIN2	orange	PIN2
VB+	PIN10	brown	PIN10
VB-	PIN15	black	PIN15
SD+	PIN9	blue	PIN9
SD-	PIN14	purple	PIN14
Shielding	Shell	Shielding wire	Shell

Corresponding accessory: ENCHA-KH

Wiring drawing

MOT-005-LL-KA-D

Wire Specification: 4C*20AWG 300V standard cable
20AWG cross sectional area 0.5189mm²

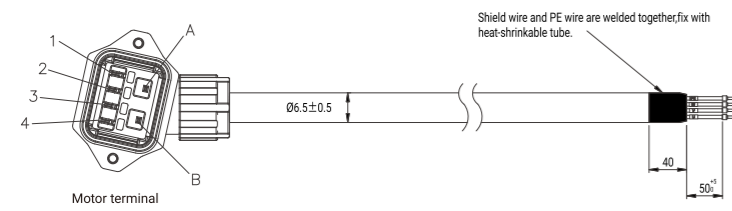

MOT-005-LL-KA-DF		
Signal	Motor side	Color
U	PIN1	white
W	PIN2	black
V	PIN3	red
PE	PIN4	Yellowgreen+Shielding

Corresponding accessory: MOT/MOTF-005-KA
Corresponding flexible cable: MOTF-005-LL-KA-D
Wire spec: 4C*20AWG 300V flexible drag chain cable
Wire diameter: 6.5±0.5mm

MOT-005-LL-KA-DF

Wire Specification: 4C*20AWG 300V standard cable shield
20AWG cross sectional area 0.5189mm²

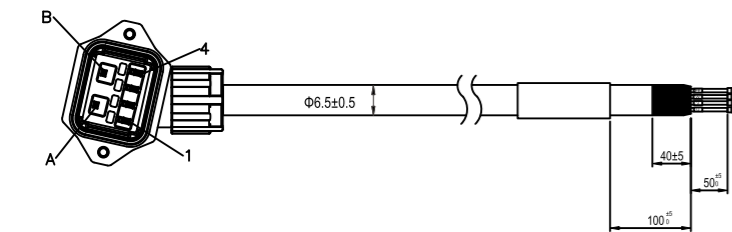

MOT-005-LL-KA-DF		
Signal	Motor side	Color
U	PIN1	white
W	PIN2	black
V	PIN3	red
PE	PIN4	Yellowgreen+Shielding

Corresponding accessory: MOT-005-KA-DF

MOT-005-LL-KAB-D

Wire Specification: 4C*18AWG+1P*24AWG standard cable
18AWG cross sectional area 0.8107mm²
24AWG cross sectional area 0.2047mm²

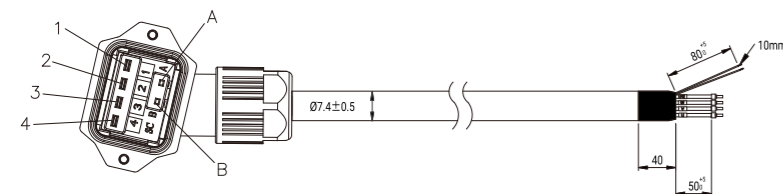

MOT-005-LL-KAB-D		
Signal	Motor side	Color
U	PIN1	white
W	PIN2	black
V	PIN3	red
PE	PIN4	Yellowgreen+Shielding
BR+	PINA	brown
BR-	PINB	blue

Corresponding accessory: MOT-011-KA
Corresponding flexible cable: MOTF-005-LL-KAB-D
Wire spec: 4C*18AWG+1P*24AWG flexible drag chain cable, shield flex
Wire diameter: 7.4±0.5mm

MOT-005-LL-KAB-DF

Wire Specification: 4C*18AWG+1P*24AWG standard cable
18AWG cross sectional area 0.8107mm²
24AWG cross sectional area 0.2047mm²

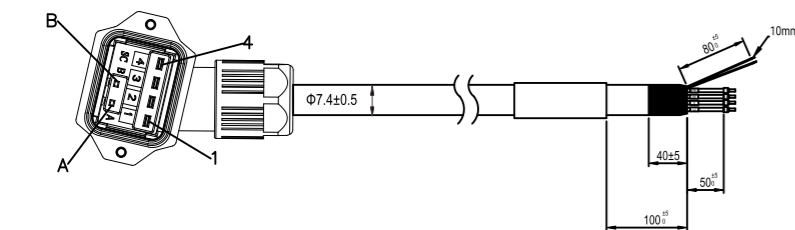

MOT-005-LL-KAB-DF		
Signal	Motor side	Color
U	PIN1	white
W	PIN2	black
V	PIN3	red
PE	PIN4	Yellowgreen+Shielding
BR+	PINA	brown
BR-	PINB	blue

Corresponding accessory: MOT-005-KAB-DF

Wiring drawing

MOT-011-LL-KA-D

Wire Specification: 4C*16AWG 300V standard cable
16AWG cross sectional area 1.318mm²

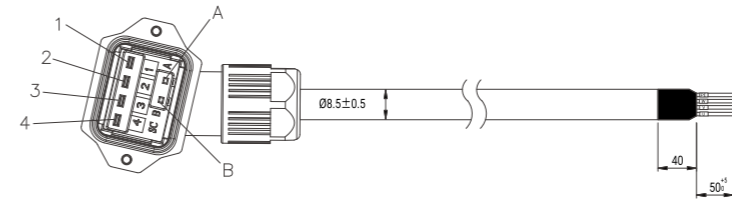

MOT-011-LL-KA-D		
Signal	Motor side	Color
U	PIN1	white
W	PIN2	black
V	PIN3	red
PE	PIN4	Yellowgreen+Shielding

Corresponding accessory: MOT-011-KA
Corresponding flexible cable: MOTF-011-LL-KA-D
Wire spec: 4C*16AWG 300V flexible drag chain cable
Wire diameter: 8.5±0.5mm

MOT-011-LL-KA-DF

Wire Specification: 4C*16AWG 300V Shielding, standard cable shield (OD<9mm)
16AWG cross sectional area 1.318mm²

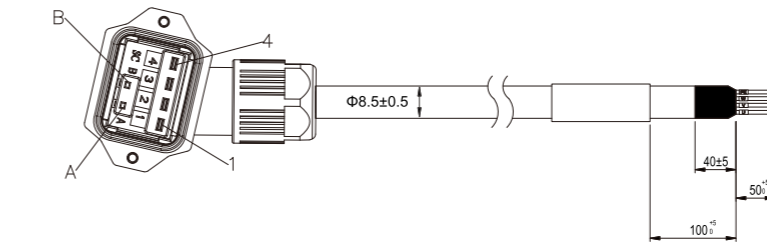

MOT-011-LL-KA-DF		
Signal	Motor side	Color
U	PIN1	white
W	PIN2	black
V	PIN3	red
PE	PIN4	Yellowgreen+Shielding

Corresponding accessory: MOT-011-KA-DF

MOT-011-LL-KAB-D

Wire Specification: 4C*16AWG+1P*24AWG standard cable
16AWG cross sectional area 1.318mm²
24AWG cross sectional area 0.2047mm²

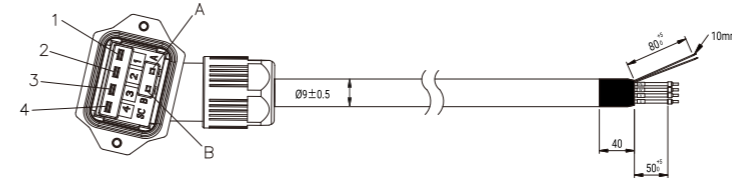

MOT-011-LL-KAB-D		
Signal	Motor side	Color
U	PIN1	white
W	PIN2	black
V	PIN3	red
PE	PIN4	Yellowgreen+Shielding
BR+	PINA	brown
BR-	PINB	blue

Corresponding accessory: MOT-011-KA
Corresponding flexible cable: MOTF-011-LL-KAB-D
Wire spec: 4C*16AWG+1P*24AWG flexible drag chain cable
Wire diameter: 9±0.5mm

MOT-011-LL-KAB-DF

Wire Specification: 4C*16AWG+1P*24AWG Shielding, standard cable, shield (OD<9mm)
16AWG cross sectional area 1.318mm²
24AWG cross sectional area 0.2047mm²

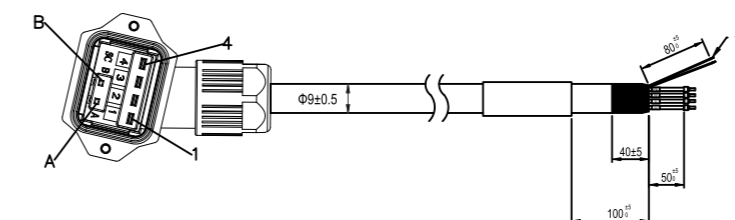

MOT-011-LL-KAB-DF		
Signal	Motor side	Color
U	PIN1	white
W	PIN2	black
V	PIN3	red
PE	PIN4	Yellowgreen+Shielding
BR+	PINA	brown
BR-	PINB	blue

Corresponding accessory: MOT-011-KAB-DF

Wiring drawing

MOT-020-LL-KA-D

Wire Specification: 4*13AWG standard cable
13AWG cross sectional area 2.627mm²

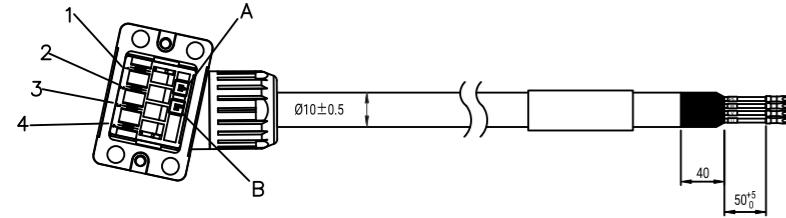

MOT-020-LL-KA-D		
Signal	Motor side	Color
U	PIN1	white
W	PIN2	black
V	PIN3	red
PE	PIN4	Yellow green+Shielding

Corresponding accessory: MOT-KA (OD < 11mm)
Corresponding flexible cable: MOTF-020-LL-KA-D
Wire spec: 4*13AWG flexible drag chain cable
Wire diameter: 10 ± 0.5mm

MOT-020-LL-KAB-D

Wire Specification: 4C*13AWG+1P*20AWG standard cable
13AWG cross sectional area 2.627mm²
20AWG cross sectional area 0.5189mm²

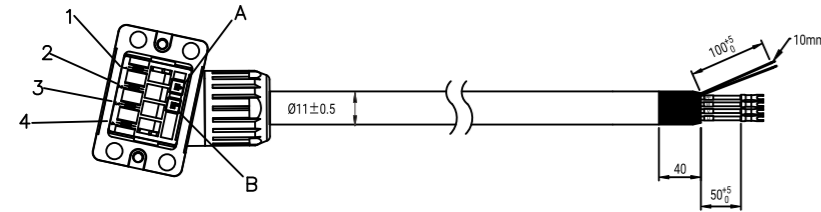

MOT-020-LL-KAB-D		
Signal	Motor side	Color
U	PIN1	white
W	PIN2	black
V	PIN3	red
PE	PIN4	Yellow green+Shielding
BR+	PINA	brown
BR-	PINB	blue

Corresponding accessory: MOT-KA (OD ≥ 11mm)
Corresponding flexible cable: MOTF-020-LL-KA-D
Wire spec: 4C*13AWG+1P*20AWG flexible drag chain cable
Wire diameter: 11 ± 0.5mm

MOT-020-LL-KL-SP

Wire Specification: UL2586 4x13AWG standard cable
13AWG cross sectional area 2.627mm²

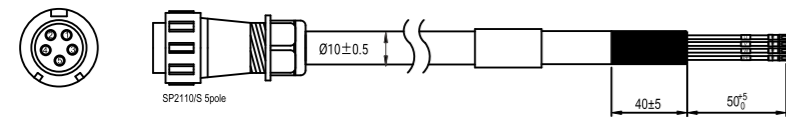

MOT-020-LL-KL-SP		
Signal	Motor side SP2110/S Spole	Color
U	PIN1	white
V	PIN2	red
W	PIN3	black
PE+Shielding	PIN4	Yellow green +shielding
NC	PIN5	NC

Corresponding accessory: MOT-020-KL-SP
Corresponding flexible cable: MOTF-020-LL-KL-SP
Wire spec: 4*13AWG flexible drag chain cable
Wire diameter: 10 ± 0.5mm

MOT-030-LL-KA-D

Wire Specification: 4*12AWG standard cable
12AWG cross sectional area 3.332mm²

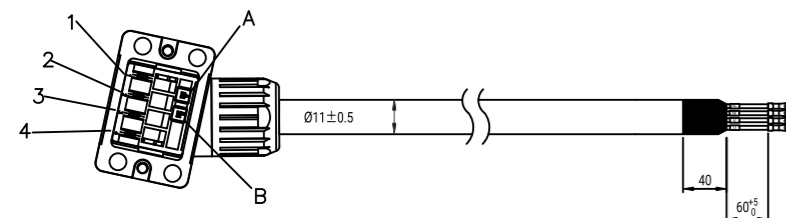

MOT-030-LL-KA-D		
Signal	Motor side	Color
U	PIN1	white
W	PIN2	black
V	PIN3	red
PE	PIN4	Yellow green+Shielding

Corresponding accessory: MOT-KA (OD ≥ 11mm)
Corresponding flexible cable: MOTF-030-LL-KA-D
Wire spec: 4*12AWG flexible drag chain cable
Wire diameter: 11 ± 0.5mm

Wiring drawing

MOT-030-LL-KAB-D

Wire Specification: 4C*12AWG+1P*20AWG standard cable
12AWG cross sectional area 3.332mm²
20AWG cross sectional area 0.5189mm²

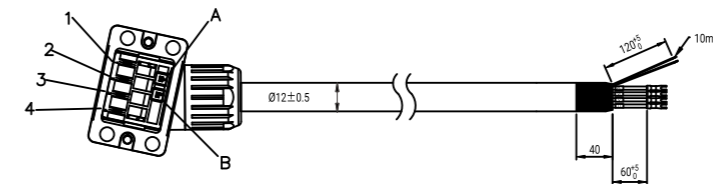

MOT-030-LL-KAB-D		
Signal	Motor side	Color
U	PIN1	white
W	PIN2	black
V	PIN3	red
PE	PIN4	Yellow green+Shielding
BR+	PINA	brown
BR-	PINB	blue

Corresponding accessory: MOT-KA (OD ≥ 11mm)
Corresponding flexible cable: MOTF-030-LL-KAB-D
Wire Specification: 4C*12AWG+1P*20AWG flexible drag chain cable
Wire diameter: 12 ± 0.5mm

MOT-040-LL-LJ51

Wire Specification: 3C*10AWG+3*19AWG
10AWG cross sectional area 5.26mm²
19AWG cross sectional area 0.5667mm²

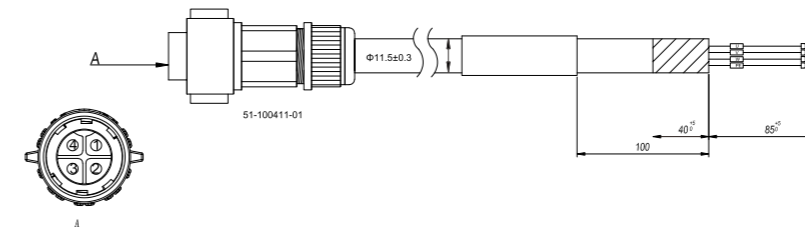

MOT-040-LL-LJ51		
Signal	Motor side	Color
U	PIN1	white
V	PIN4	red
W	PIN3	black
PE+Shielding wire	PIN2	Yellowgreen+Shielding

MOT-040-LL-LS/MOT-080-LL-LS

Wire Specification: 8AWG (Single wire)
8AWG cross sectional area 8.37mm²

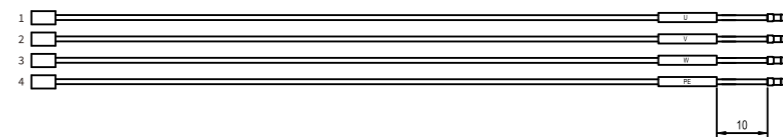

MOT-040-LL-LS/MOT-080-LL-LS		
Signal	Motor side LCA/060 F	Color
U	PIN1	white
V	PIN2	red
W	PIN3	black
PE	PIN4	Yellow green

Corresponding accessory: MOT-040-LS

BRA-LL-KL

Wire Specification: 2C*20AWG
20AWG cross sectional area 0.5189mm²

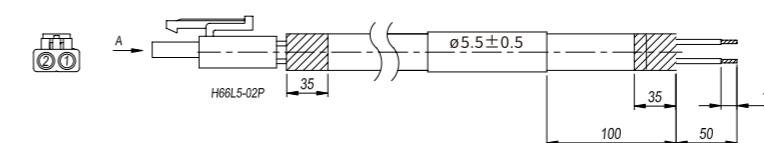

BRA-LL-KL		
Signal	Motor side H66L5-02P	Color
BR+	PIN1	red
BR-	PIN2	blue

Corresponding accessory: BRA-KL
Corresponding flexible cable: BRAF-LL-KL
Wire spec: 2C*20AWG (72/0.10T) 5 million times
Wire diameter: 5.5 ± 0.5mm